

# Verso CF 1000 U C5

Nominal air flow according to ErP 2018, m <sup>3</sup> /h	1055
Nominal air flow according to ErP 2018, l/s	293
Panel thickness, mm	50
Unit weight, kg	269
Supply voltage HE, V	3~400
Supply voltage HW, V	1~230
Maximal operating current HE, A	9,5
Maximal operating current HW, A	3,3
Filters dimensions BxHxL, mm	800x400x46
Electric power input of the fan drive at maximum flow rate, W	178
Electric air heater capacity, kW / Δt, °C	4,5 / 12,5
Maintenance space, mm	800
Control system	C5



### Acoustic data

#### A-weighted sound power level L<sub>wa</sub>, dB(A) at nominal flow rate

Supply inlet	56
Supply outlet	74
Exhaust inlet	57
Exhaust outlet	74
Casing	54

#### A-weighted sound pressure level L<sub>pa</sub>, dB(A)

10 m<sup>2</sup> normally isolated room, distance from casing – 3 m.

Surroundings	43
--------------	----

### Performance (Verso CF 1000 UH data)

Supply air filter F7, exhaust air filter M5

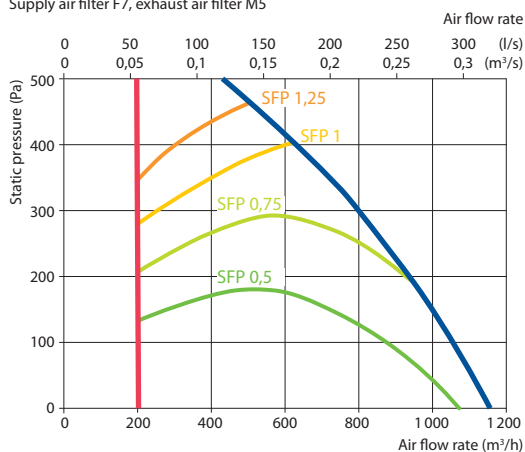

### Temperature efficiency

	Winter					Summer		
Outside temperature, °C	-23	-15	-10	-5	0	25	30	35
After heat exchanger, °C	15,2	16,0	16,8	17,1	18,0	22,6	23,5	24,7

indoor +22°C, 20% RH

### Changeover water/ DX heating – cooling exchanger (HCW/HCDX)

	Winter	Summer	Winter	Summer
Water temperature in/out, °C	60/40	7/12	–	–
Condensation/evaporation T, °C	–	–	45	45/5
Capacity, kW	2,4	6,8	2,4	7,3
Maximal capacity, kW	8,7	8,9	5,2	9,9
Pressure drop, kPa	1,8	34,5	–	–
Air temperature in/out, °C	15,2 / 22	30 / 18	15,2 / 22	30 / 18
Connection, " / mm	½		½ / 22	

Summer: +30°C/ 50%

#### Shown as right (R1)

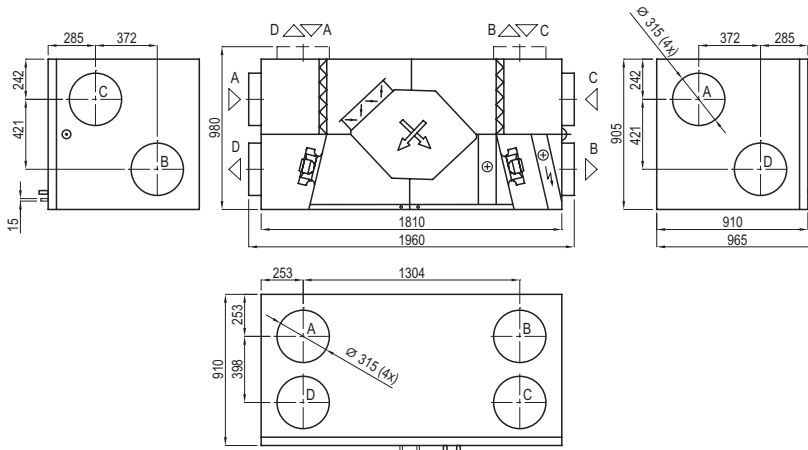

#### Shown as left (L1)

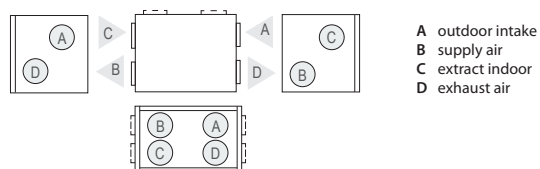

### Accessories

Closing damper	AGUJ-M-315+LF24/LM24
Silencer	A/D AGS-315-100-900-M
	B/C AGS-315-100-1200-M
PPU	PPU-HW-3R-15-0,63-W2
Water cooler	DCW-0,9-6
2-way valve	VVP47.15-2,5+SSP61
DX cooler	DCF-0,9-6
Cooling unit	MOU-18HFN8+KA8140