

# Domekt CF 400 V C6M

Maximal air flow, m <sup>3</sup> /h	422
Maximal air flow, l/s	117
Reference flow rate, m <sup>3</sup> /s	0,082
Reference pressure difference, Pa	50
SPI, W/(m <sup>3</sup> /h)	0,28
Thermal efficiency of heat recovery, %	89
Electric air heater capacity, kW / Δt, °C	0,5/4,9
Electric preheater capacity, kW / Δt, °C	1/9,9
Supply voltage, V	1~230
Maximal operating current HE, A	8,1
Power supply cable, mm <sup>2</sup>	3×1,5
Electric power input of the fan drive at maximum flow rate, W	123
Electric power input of the fan drive at reference flow rate, W	48
Noise power level, L <sub>WA</sub> , dB(A)	45
Noise pressure level, L <sub>PM</sub> , dB(A), (3 m)	34
Filters dimensions B×H×L, mm	350×220×46
Unit dimensions B×H×L, mm	585×750×598
Maintenance space, mm	750
Unit weight, kg	55



## Performance

Unit with standard equipment

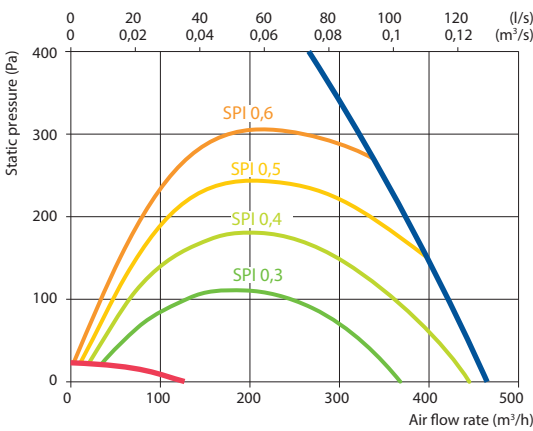

## Accessories

Closing damper	AGUJ-M-160+LF230/CM230
Silencer	ODA/EHA AGS-160-50-600-M
	SUP/ETA AGS-160-50-900-M
Water heater	DH-160
PPU	PPU-HW-3R-15-0,4-W2
2-way valve (heater)	VVP47.10-0,4+SSF161.05HF
Water cooler	DCW-0,4-3
2-way valve (cooler)	VVP47.10-1,6+SSF161.05HF
Outdoor grill	LD-160
Water heater-cooler	DHCW-160
DX cooler	DCF-0,4-3
Cooling unit	MOU-12HFN8a+KA8140

## Temperature efficiency

	Winter					Summer		
Outdoor temperature, °C	-23	-15	-10	-5	0	25	30	35
After heat exchanger*, °C	18,3*	18,9*	19,5*	19,5*	19,5	22,3	22,9	23,5

indoor +22 °C, 20 % RH

\* calculations made after evaluation of the preheater.

Shown as right (R1)

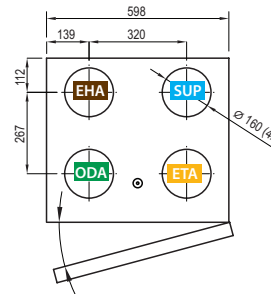
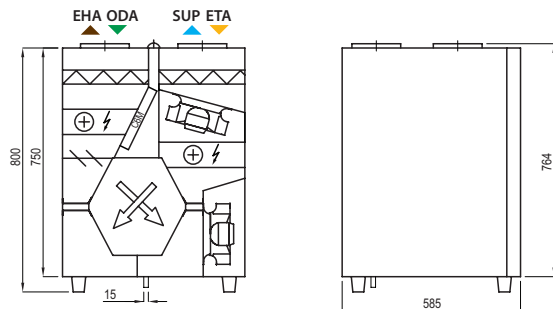

Shown as left (L1)

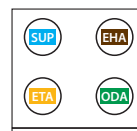

▶ ODA – outdoor intake    ▶ SUP – supply air    ▶ ETA – extract indoor    ▶ EHA – exhaust air