

# KLASIK

## INSTALLATION MANUAL





# CONTENT

<b>1. INTRODUCTION</b> .....	4
1.1. Safety Requirements .....	4
1.2. Unit Types and Sizes .....	5
1.3. Unit Components and Sections .....	8
1.3.1. Filter section .....	8
1.3.2. Fan section .....	10
1.3.3. Counter-Flow Heat Exchanger (CF) Section .....	11
1.3.4. Rotary heat exchanger (R) Section .....	12
1.3.5. Liquid coupled heat exchanger .....	13
1.3.6. Recirculation Section .....	14
1.3.7. Cooler and Heater Sections .....	15
1.3.8. Air Dampers .....	16
1.3.9. Silencers .....	17
1.3.10. Humidifier section .....	18
1.4. Inspection Sides .....	19
<b>2. UNIT TRANSPORTATION AND STORAGE</b> .....	21
<b>3. MECHANICAL INSTALLATION</b> .....	26
3.1. Requirements for Mounting Location and Installation Base .....	26
3.2. Inspection Area .....	27
3.3. Door Handles and Hinges .....	29
3.4. Connection of Sections .....	30
3.5. Installation of Heating/Cooling Devices .....	32
3.6. Connection of a Condensate Drain .....	35
3.7. Connection to Air Ducts .....	36
3.8. Outdoor Units .....	38
<b>4. ELECTRICAL INSTALLATION</b> .....	41
4.1. Requirements for Electrical Connection .....	41
4.2. Connection of Electrical Components .....	44
4.2.1. Connection terminals of KLASIK RA air handling units .....	50
4.3. Control Panel Installation .....	51
4.4. Connection of Cables and Wires Between Sections .....	53
4.5. Connecting the Unit to the Internal Computer Network or the Internet .....	55
<b>5. COMMISSIONING AND INSPECTION OF THE UNIT</b> .....	58
5.1. Control panel C5.1 .....	59
5.2. Starting the Unit With a Computer .....	63
5.3. Calibration of Clean Filters .....	65
5.4. Quick Inspection .....	67
<b>ANNEX NO. 1. ADJUSTMENT OF THE ROTARY HEAT EXCHANGER WHEEL</b> .....	68

# 1. INTRODUCTION

This Installation Manual is intended for professionals, qualified to install KLASIK air handling units. Qualified professionals are people with sufficient professional experience and knowledge of ventilation systems and installation thereof, knowledge of electrical safety requirements and having ability to perform works without endangering themselves or others.

See the KOMFOVENT website for user manuals.

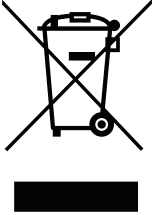
## 1.1. Safety Requirements

To avoid misunderstandings, read this Instruction Manual carefully before installing air-handling unit.

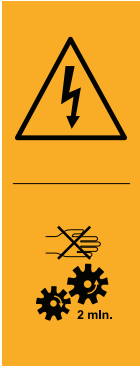
Only a qualified professional in accordance with the manufacturer's instructions and applicable legal acts and safety requirements may install air-handling units. An air handling unit is an electrical-mechanical device that contains electrical and moving parts, therefore, disregarding instructions of this manual will void the manufacturer's warranty and may also cause direct damage to property or human health.



- Before starting any tasks, make sure that the unit is unplugged from the mains.
- Use caution when performing works near internal or external heaters as their surfaces may be hot.
- Do not connect the unit to the mains unless all the external assemblies are installed completely.
- Do not connect the unit to the mains in case of any visible damage incurred during transportation.
- Do not leave foreign objects and tools inside the unit.
- It is forbidden to operate air-handling units in areas with potentially explosive atmospheres.
- Use appropriate safety equipment (gloves, goggles) when performing installation or repair works.



This symbol indicates that this product may not be disposed of with your household waste as specified in WEEE Directive (2002/96/EC) and national laws. This product should be handed over to a designated collection point or to an authorised collection site for recycling waste electrical and electronic equipment (EEE). Improper handling of this type of waste could have a negative impact on the environment and human health due to potentially hazardous substances that are generally associated with electrical and electronic equipment. At the same time, your cooperation in the correct disposal of this product will contribute to the effective usage of natural resources. For more information about where you can drop off your waste equipment for further recycling, contact your city authorities, waste management organisations, approved WEEE scheme or your household waste disposal service.



Symbols indicate zones or devices inside the unit where there is a potential risk of electrical shock or health damage. Yellow stickers can be found on various doors, panels and covers on the exterior or inside of the unit. Use extra caution and appropriate safety equipment when working inside the sections marked by such symbols.

## 1.2. Unit Types and Sizes

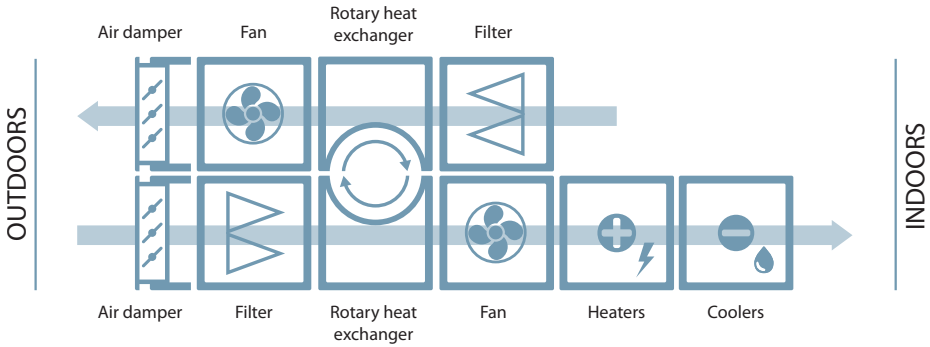
An air-handling unit is a device designed to ensure good ventilation in the premises. An air-handling unit removes indoor air containing carbon dioxide, various allergens or dust, while replacing it with filtered fresh air from outside. As the outside air is usually colder or warmer than the air within the premises, an integrated recuperator (heat exchanger) collects thermal energy from the indoor air and transfers the majority of it to the supply air. When a recuperator is not capable of reaching a desired temperature, additional heaters or coolers may be activated.



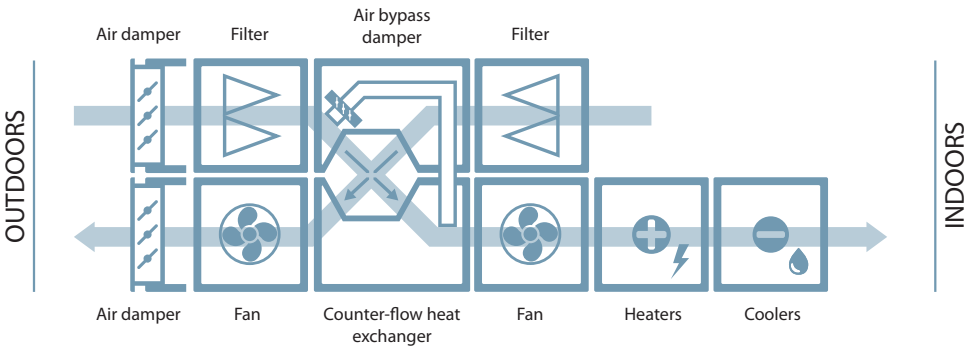
Heat exchangers and heaters (or coolers) are designed to compensate for heat/cool losses during ventilation, therefore, we do not recommend using this unit as the main heating/cooling source. The unit may fail to reach a user-defined supply air temperature when the actual temperature in the premises differs significantly from the temperature set point, since this will lead to inefficient operation of a heat exchanger.

All KLASIK air handling units are divided into 3 groups according to the type of recuperator (heat exchanger) used:

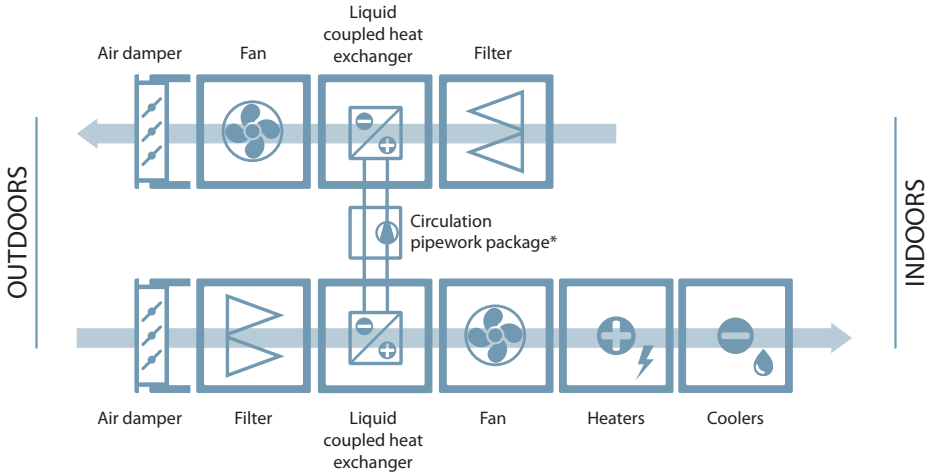
**KLASIK R** – air handling units with rotary heat exchangers. Rotating wheel (rotor) of a rotary heat exchanger collects heat or cold from the indoor air and transfers it to the fresh supply air. Recovered heat/cold capacity is changed by adjusting the rotor speed. When heat recovery is not required, the wheel stops.



**KLASIK CF** – air handling units with counter-flow recuperators (heat exchangers). Plates of a heat exchanger come in contact with different air flows and so heat exchange between extracted and incoming fresh supply air takes place. Amount of recovered heat or cold is controlled by adjusting the air bypass damper position. When recuperation is not required, the air bypass damper is opened and the heat exchanger is closed. This way, the outdoor air bypasses the heat exchanger and flows directly in to the premises.

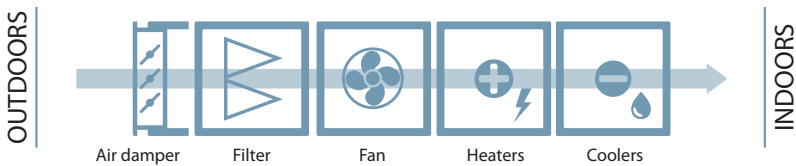


**KLASIK RA** – air handling units with a liquid coupled heat exchanger that uses a liquid heat carrier for heat exchange. The heat exchanger consists of two coils (in the supply and extract air flows) connected via a circulation pipework unit (sold separately) and filled with a non-freezing heat carrier, usually a mixture of water and glycol. The amount of heat/cold recovered is adjusted by changing the speed of the circulation pump or the position of the three-way valve. RA air handling units are usually used, when it is needed to separate the supply and exhaust air streams. For this purpose, the unit is separated into two independent supply and exhaust air assemblies that can be installed further apart or even on different floors.



\* Sold separately. It is recommended to use a pipework package (PPU-LCHX) made by Komfovent.

**KLASIK S** – air handling units without heat exchangers, intended solely for air supply to the premises. Fresh outdoor air is heated/cooled to desired temperature with heating/cooling devices installed in the unit or air ducts.



KLASIK units come in several sizes. Each size is designed for a specific air volume range:

Unit size	Minimum air volume, m <sup>3</sup> /h	Maximum air volume, m <sup>3</sup> /h
1	1 000	3 000
2	2 000	5 000
3	3 000	7 000
4	4 000	8 900
5	5 500	14 000
6	7 250	17 000
7	9 000	22 000
8	12 000	27 000
9	16 000	30 000
10	20 000	32 000
11	24 000	38 500
12	29 000	100 000

Maximum air volume may be limited according to the order, for example, if lower power fans are used or higher air volume is not required by the project requirements. For exact maximum air volume see the technical data print-out of the specific unit.

## 1.3. Unit Components and Sections

KLASIK air handling units are assembled from separate sections. Depending on the order and unit size, sections may be pre-assembled in a factory or transported separately. Type of each section is marked with a label attached to the section door. The following are the main sections of the air handling unit. For equipment and number of sections in each unit see the technical data print-out of the specific unit.

### 1.3.1. Filter section

Air filters are intended for removing dust, bacteria and other fine particles from the supplied and extracted air. KLASIK air handling units may be fitted with various types of filters (bag, compact, Hepa). Also, filters can have different filtration classes<sup>1</sup>, i.e. intended for removing particles of different sizes. In general, supply air ducts are equipped with better filtering class filters than extracted air ducts, since the cleaned outdoor air is supplied to the premises.

Filter type, dimensions, filtering class, number and exact location is specified in the technical data print-out for the specific unit.

Depending on the filter type, its clamping construction inside of the unit may also differ. In most cases, to insert/remove filters, it will be needed to push handles at the top and bottom of the filter section forward to release a filter clamping device. Filters are removed/inserted one by one (number of filters depends on the unit size). Once the filters are replaced/inserted, handles are retracted and the filter clamping device presses the filters to the gaskets.



**When inserting filters, make sure that their pockets are upright, filter frames are tightly seated and gaskets are intact.**

<sup>1</sup> Depending on the order.



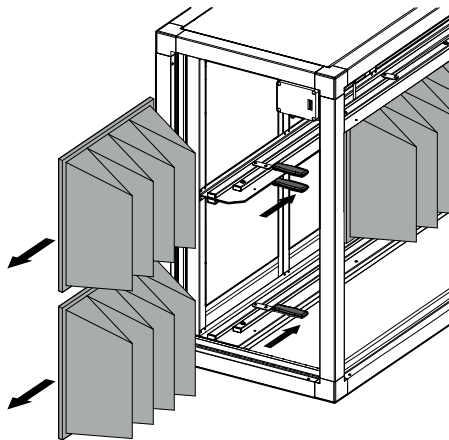


Fig. 1. Bag or compact filter clamping device example

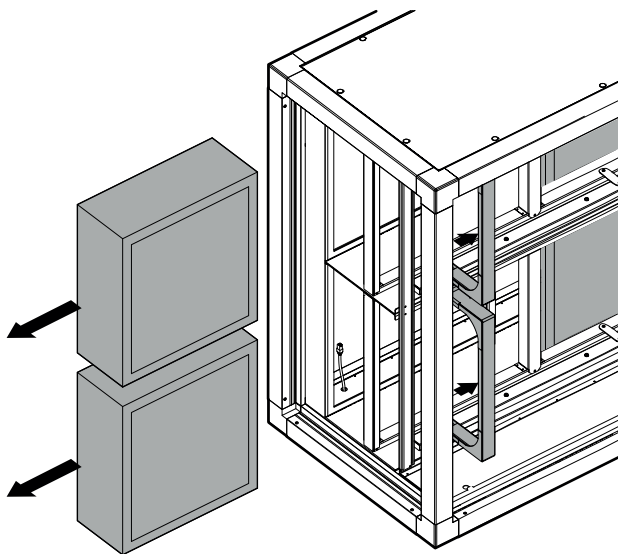


Fig. 2. Hepa or compact filter clamping device example

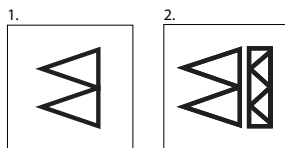


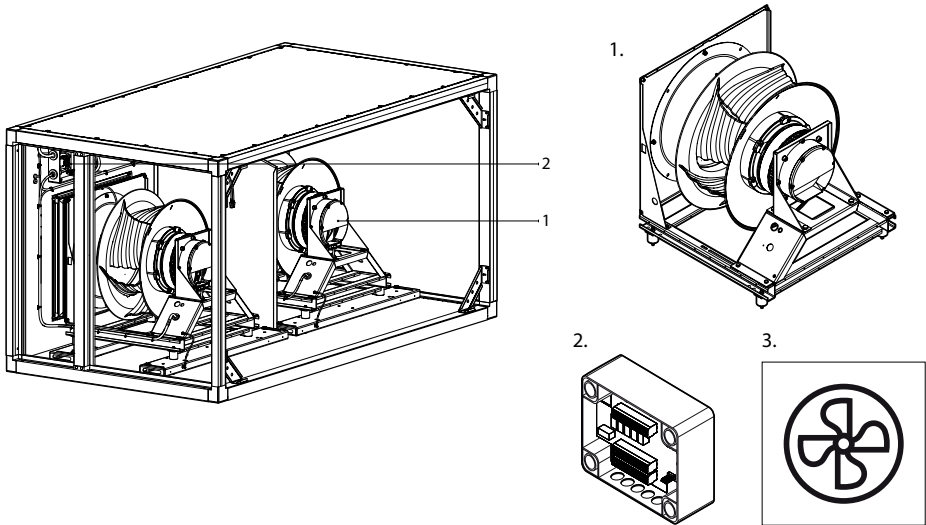
Fig. 3. Filter section labels

1 – section with one row of filters, 2 – section with additional pre-filters

### 1.3.2. Fan section

KLASIK R, CF and RA air handling units have two fan sections. In KLASIK S air handling units there is one fan section. Depending on the unit size, it may be several fans integrated into one fan section. Fans are connected to an electronic circuit board fitted in the same section. EC fans are controlled by direct 0..10V signal and PM motors with frequency inverters communicate with C5 controller via Modbus.

Fan type, count and characteristics are specified in the technical data print-out for the specific unit.

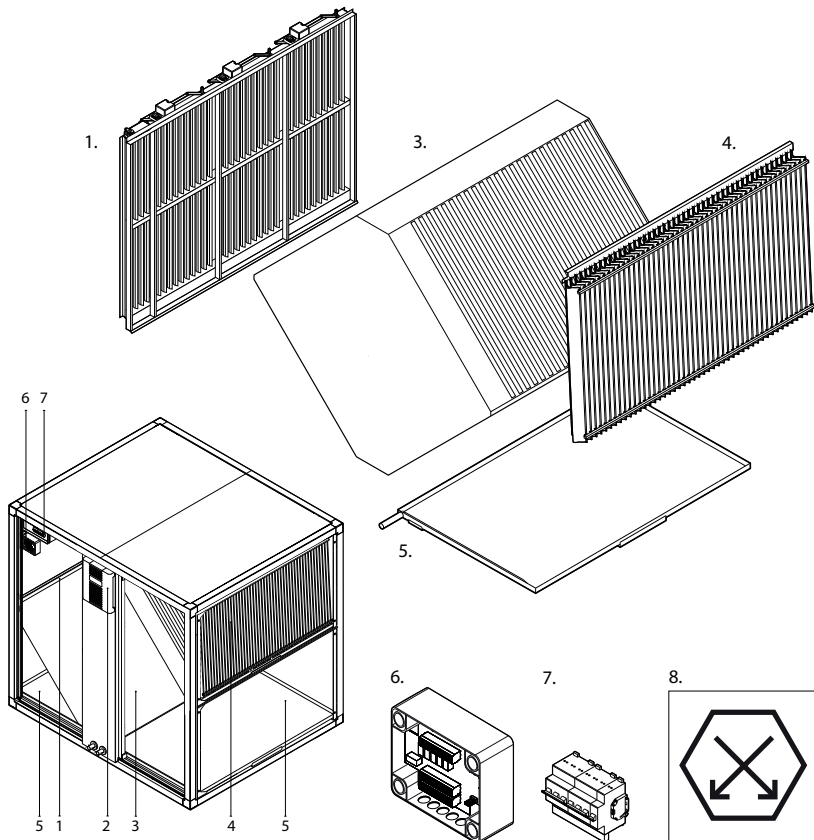


**Fig. 4.** Fan section

1 – fan assembly with an installation frame 2 – fan control board (C5\_VM), 3 – fan section label

### 1.3.3. Counter-Flow Heat Exchanger (CF) Section

Due to heat exchange and condensation in counter-flow heat recovery units, heat exchangers may freeze at lower air temperatures. To prevent freezing or to defrost, a heat exchanger is equipped with an air bypass damper or a multi-stage damper system (according to the order). Formed condensate flows to condensate trays. If air velocity in the air handling unit is high ( $> 2 \text{ m/s}$ ), an optional drop eliminator is installed, which prevents condensate from entering other parts of the unit or air ducts. Recuperator section is also fitted with an automation box to which many of the main electrical components are connected (see Chapter "Connection of Electrical Components").

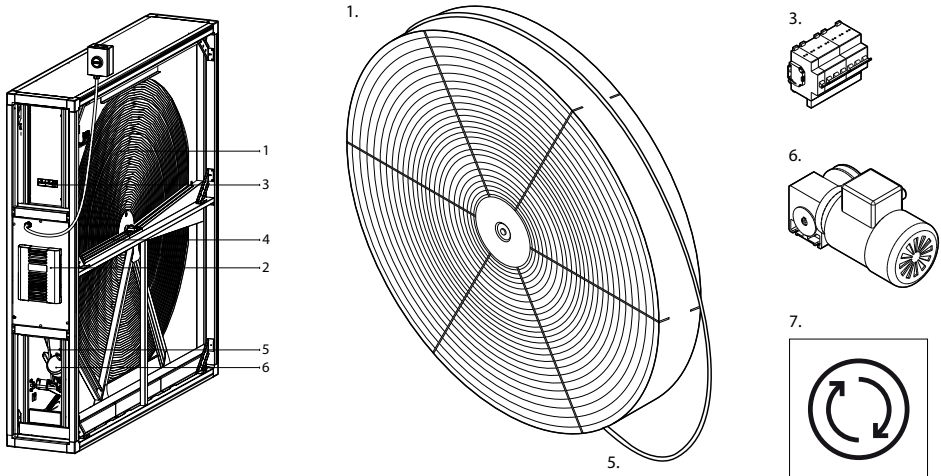


**Fig. 5.** Counter-flow heat exchanger (CF) section

- 1 – air bypass damper or a multi-stage damper system, 2 – automation box, 3 – counter-flow heat exchanger, 4 – drop eliminator, 5 – condensate trays, 6 – air bypass control board (C5\_PM or C5\_MDS), 7 – automatic switch, 8 – CF section label

### 1.3.4. Rotary heat exchanger (R) Section

Rotor wheel of a rotary recuperator is belt driven by an electric gear motor. Brush seals are installed at the perimeter of a rotating wheel and between air flows to prevent different air flows from mixing. Heat exchanger section is also fitted with an automation box to which many of the main electrical components are connected (see Chapter "Connection of Electrical Components").

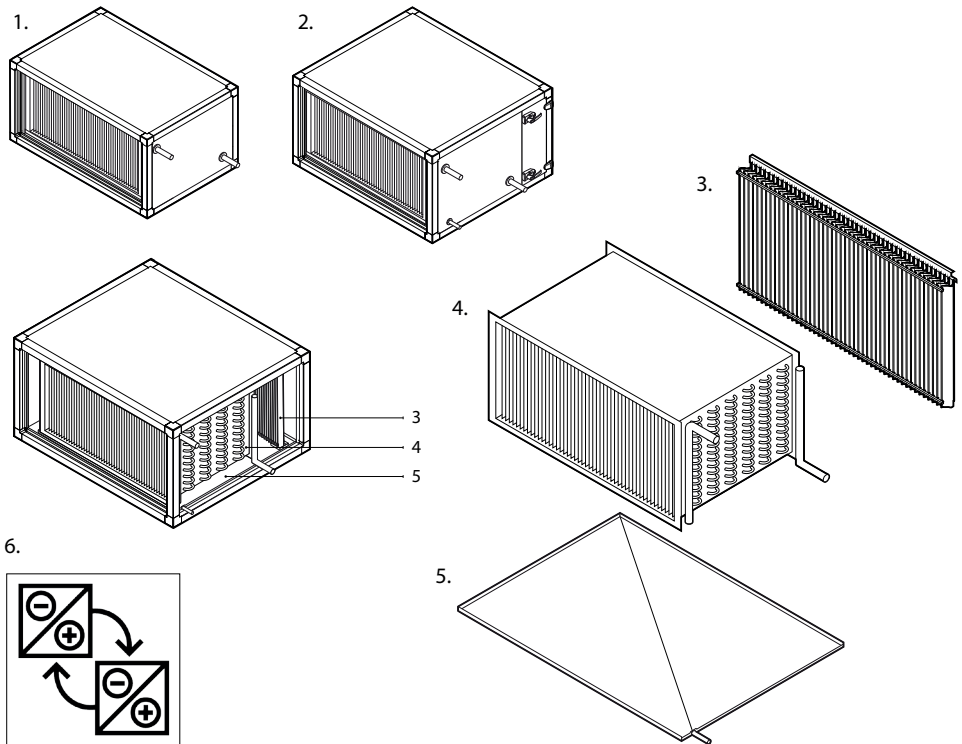


**Fig. 6.** Rotary heat exchanger section

1 – rotor wheel, 2 – automation box, 3 – automatic switch, 4 – rotor wheel brush seals, 5 – rotor belt, 6 – rotor gear motor, 7 – rotor section label

### 1.3.5. Liquid coupled heat exchanger

A liquid coupled heat exchanger used for airflow separation consists of two coils (radiators) in which an antifreeze mixture of water and glycol circulates. Coils are located in separate sections that should be installed in the supply or extract air flows. Additionally, a drop eliminator is placed inside the coil section of the extract airflow to prevent excess condensate from entering the ducts, so an additional drainage pipe must be connected to this section (see section “Connection of a condensate drain”).



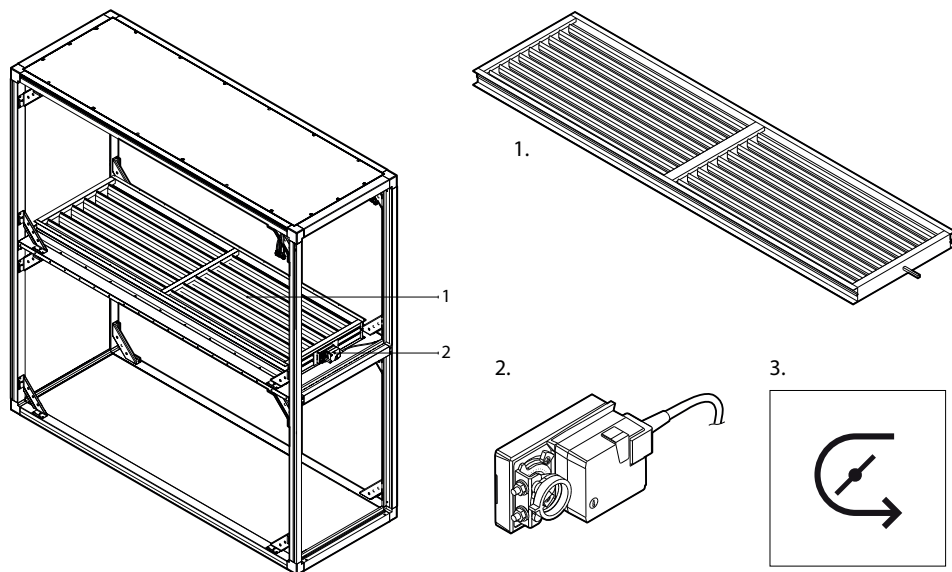
**Fig. 7.** Sections of liquid coupled heat exchanger

- 1 – coil sections of the supply airflow, 2 – coil sections of the extract airflow, 3 – drop eliminator, 4 – exchanger coil, 5 – condensate drip pan, 6 – marking label of liquid coupled heat exchanger section

KLASIK RA units can be designed as a single (mono-block) unit, or divided into two separate assemblies (for supply and exhaust airflows).

### 1.3.6. Recirculation Section

Recirculation section is intended for mixing extract and supply air for heating or cooling thereof by reducing energy consumption of heaters/coolers.

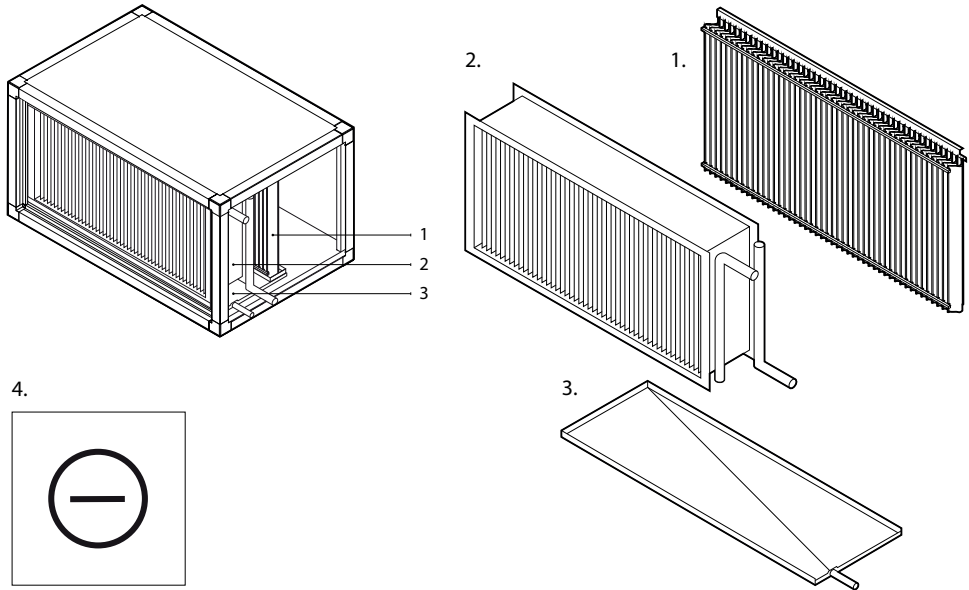


**Fig. 8.** Recirculation section

1 – air mixing damper, 2 – damper actuator, 3 – recirculation section label

### 1.3.7. Cooler and Heater Sections

Cooler section is fitted with water or direct evaporation (DX) coolers as well as combined heater/cooler heat exchangers. Cooling air causes condensation, therefore, a condensate tray is installed under a heat exchanger. If air velocity in the air handling unit is high ( $> 2$  m/s), an optional drop eliminator is installed, which prevents condensate from entering other parts of the unit or air ducts.



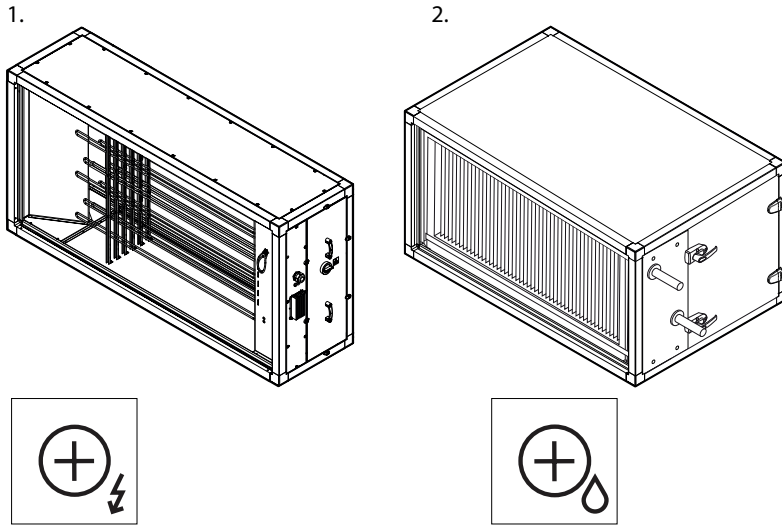
**Fig. 9.** Cooler section

1 – drop eliminator, 2 – coil for water/refrigerant 3 – condensate tray, 4 – cooler section label



**It is necessary to use water-ethylene glycol mixture to prevent freezing of water in coolers or combined heater/cooler coils.**

Depending on the order, electric or water heaters may be selected. An electric heater section is fitted with heater control electronics and the main circuit breaker (see Chapter “Requirements for Electrical Connection”). Also, there is integrated two-stage protection against overheating. A water heater is fitted with a return water temperature sensor, which protects the heat exchanger against freezing. Sensor installation procedure is described in Chapter “Installation of External Heating/Cooling Devices”.



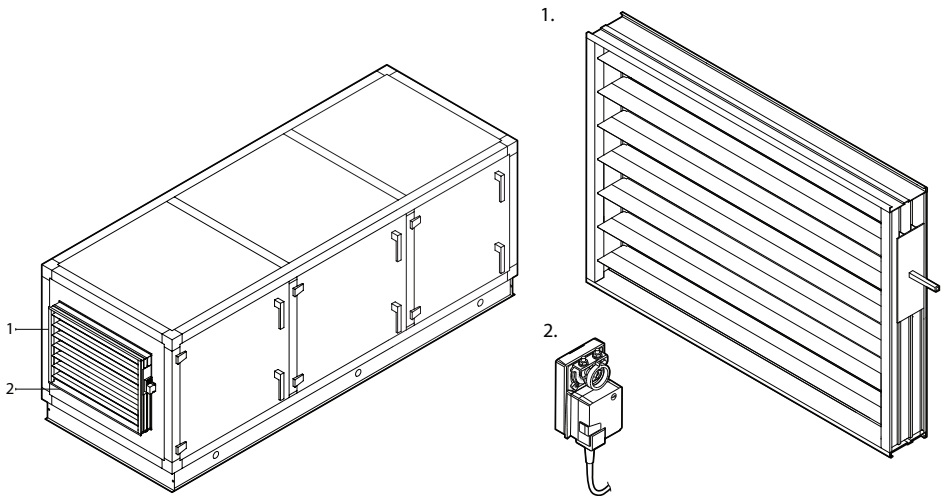
**Fig. 10.** Heater section

1 – electric heater section and label, 2 – water heater section and label

### 1.3.8. Air Dampers

Air dampers are mounted on the outside of the unit and are fastened with self-tapping screws. Air dampers are designed to isolate the unit and to protect against air flows and draughts when the unit is stopped. Damper blades are closed/opened with an electric actuator (24 V AC), the power and torque of which is selected according to a damper size. On indoor mounted units, rectangular air ducts may be connected directly to dampers. Air dampers on the outdoor air side must be insulated, preventing condensation on the cold surfaces (see Chapter "Connection of Air Ducts"). For outdoor installation, air dampers with electric actuators must be protected against environmental influences with special insulated covers or other structures. In such case the ducts must be connected to a flange of the insulated cover and not directly to the air damper.

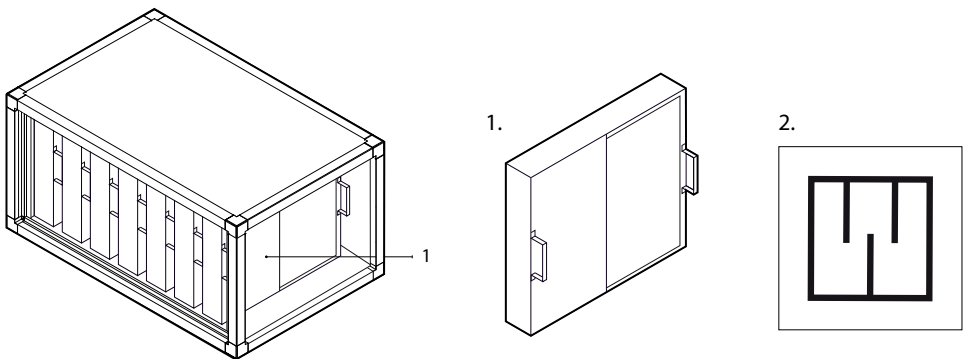




**Fig. 11.** Air closing dampers  
1 – air damper, 2 – electric damper actuator

### 1.3.9. Silencers

Noise suppressor sections are intended for reducing noise generated by an air handling unit and air flows. Depending on the unit type and location of a silencer section, suppressor sections may be separate for each air flow (e.g., for supply air only) or double, intended for both air flows. Silencer section is equipped with noise absorbing partitions which can be removed and cleaned during inspection works. Silencer section may also be equipped with an optional compact filter.



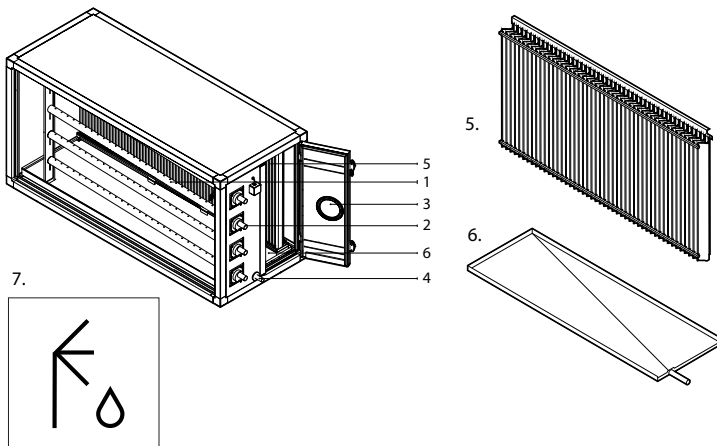
**Fig. 12.** Noise suppressor section  
1 – removable noise absorbing partitions, 2 – silencer section label

### 1.3.10. Humidifier section

KLASIK units that was ordered with humidity function can control external steam humidifier. Humidifier generates steam that reaches steam distributors located inside of the AHU in the supply airflow. A drop eliminator is placed inside the humidifier section to prevent excess condensate from entering the ducts, so an additional drainage pipe must be connected to this section (see section "Connection of a condensate drain").

In order for the humidifier to operate correctly, humidity sensors must be installed and connected to the C5 controller board (See "Electrical installation"). Humidity control function (HUM) can maintain humidity of the supply or of the indoor air – more information about this function you can find in the "KLASIK user manual".

In most cases (depending on the manufacturer) the humidifier must be installed lower than humidification section in the air handling unit, thus steam hoses will be installed with a slope towards humidifier. Maximum length of the steam hoses is also limited, thus be sure to consider these aspects when choosing the installation location of the air handling unit or humidifier.



**Fig. 13.** Humidifier section

1 – steam distributors, 2 – steam hose connection pipes, 3 – inspection window, 4 – condensate drain pipe, 5 – drop eliminator, 6 – condensate tray, 7 – humidifier section label



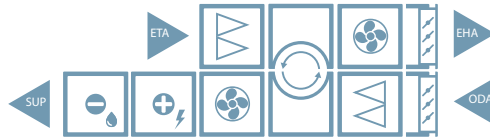
- Install the humidifier and connect it to the AHU according to the humidifier manufacturer's instructions.
- Water quality used for the humidifier must comply with country-specific hygienic requirements for drinking water and water specifications described by the humidifier manufacturer.
- For hygienic purposes, when the humidifier is on stand-by automatic drain intervals, shorter than 48 hours must be set up according to the humidifier manufacturer's instructions.
- If the air-handling unit is stopped while humidifier is still running, fans run at fixed speed until already produced water vapor is removed from the humidifier section. Blowing time depends on the capacity of humidifier and ventilation intensity and can take up to 15 minutes.

## 1.4. Inspection Sides

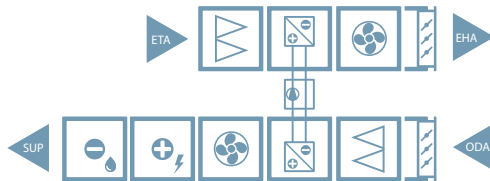
Depending on the installation position and connection of air ducts, KLASIK air handling units are available in four inspection sides. Inspection side is determined by a supply air duct (SUP) position:

**L1** Air duct for supply air connected on the left bottom side of the unit.

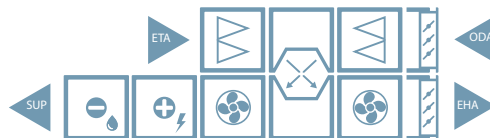
**KLASIK R**



**KLASIK RA**



**KLASIK CF**



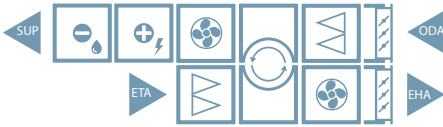
**KLASIK S**



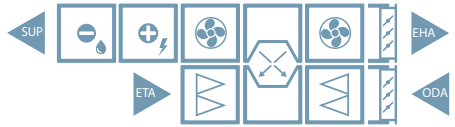
- ODA – outdoor air
- SUP – supply air
- ETA – extract air
- EHA – exhaust air

**L2 Air duct for supply air connected on the left upper side of the unit**

**KLASIK R**



**KLASIK CF**



**R1 Air duct for supply air connected on the right bottom side of the unit**

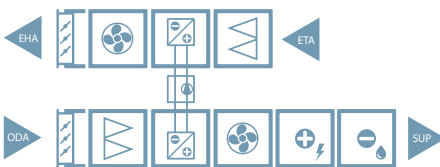
**KLASIK R**



**KLASIK CF**



**KLASIK RA**

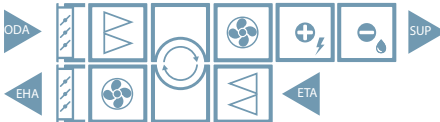


**KLASIK S**

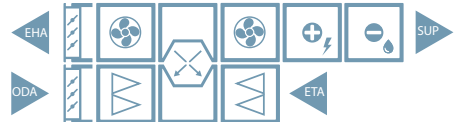


**R2 Air duct for supply air connected on the right upper side of the unit**

**KLASIK R**



**KLASIK CF**



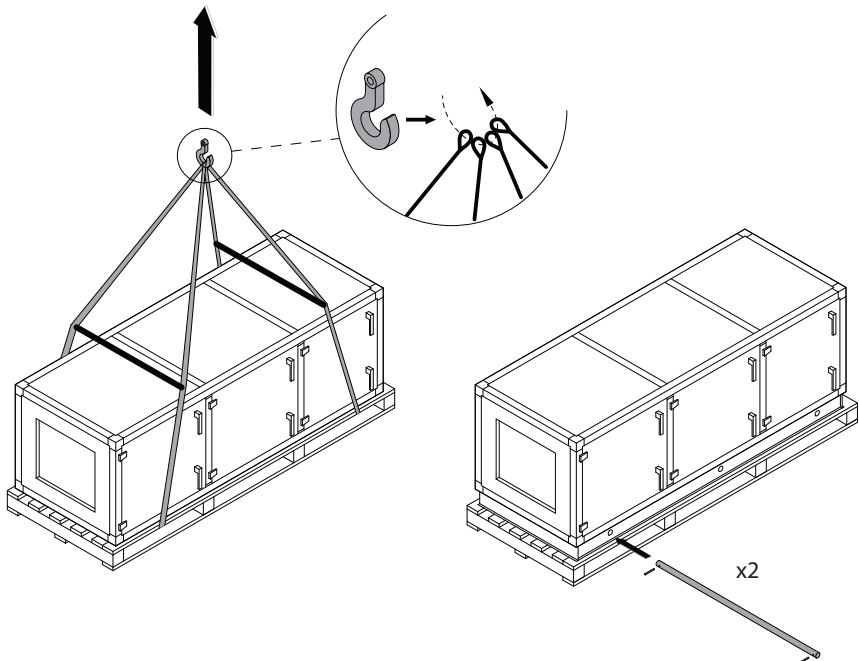
- ODA – outdoor air
- SUP – supply air
- ETA – extract air
- EHA – exhaust air

## 2. UNIT TRANSPORTATION AND STORAGE

On arrival of the ventilation unit, carefully inspect the packaging for any damage. If any mechanical or other defects are visible (e.g. wet cardboard packaging), immediately notify the carrier. If damage is significant, do not accept the goods. Notify the Seller or KOMFOVENT UAB representative<sup>1</sup> about any transportation damage within three working days.

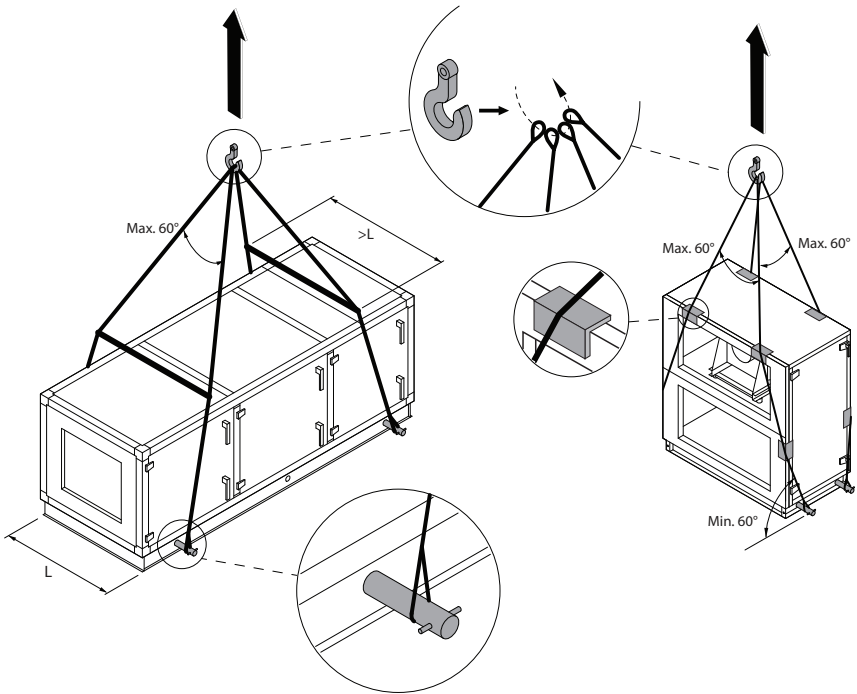
Devices must be stored in clean and dry premises, at 0–40°C temperature. Stored unit must be protected against any accidental damage as well as dust and dirt entering the unit. Other heavy items shall not be loaded on top of the stored device.

Transported units must be properly fixed and additionally protected from possible mechanical damage, rain or snow. Units shall be loaded and unloaded using a forklift or a crane. When lifting with a crane, special straps or ropes, fixed in designated areas, must be used. It must be ensured that the casing is not crushed or otherwise damaged by straps or ropes during lifting operations. Use of special supporting structures (traverses) is recommended. Individual sections of the unit shall be lifted together with an installation frame or a wooden pallet.



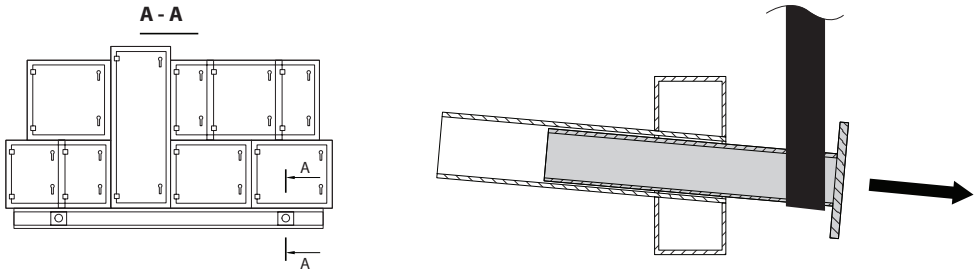
Lifting equipment (lifting tubes, belts, cables, traverses) is not included.

<sup>1</sup> KOMFOVENT UAB shall not be held liable for any damages caused by the carrier during transportation or unloading.

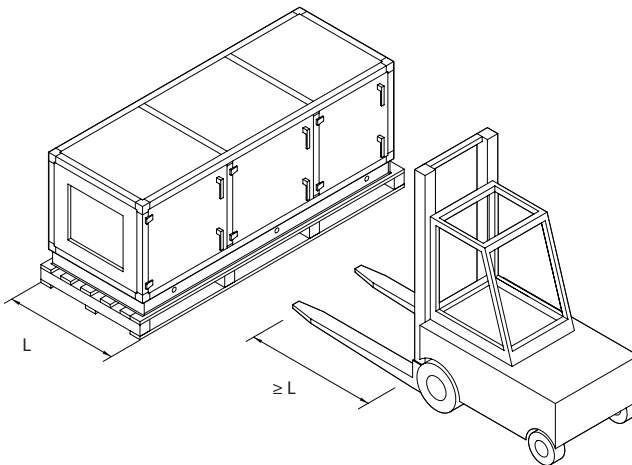


Lifting equipment (lifting tubes, belts, cables, traverses) is not included.

Special retractable holders are foreseen for lifting bulky equipment assembled on solid installation frames. These holders are placed in special openings of the installation frame; their design prevents straps from slipping out of place.



When a forklift is used for lifting or transporting the unit, its forks must be long enough to prevent the device from tipping over or to avoid mechanical damage to its bottom part. Ventilation units are heavy, therefore care must be taken during lifting, carrying or moving operations. Use personal protection equipment.



**Unloading or lifting works should be performed only by qualified person, who has a right to work with forklift or crane and with sufficient professional knowledge about lifting principles and safety requirements.**

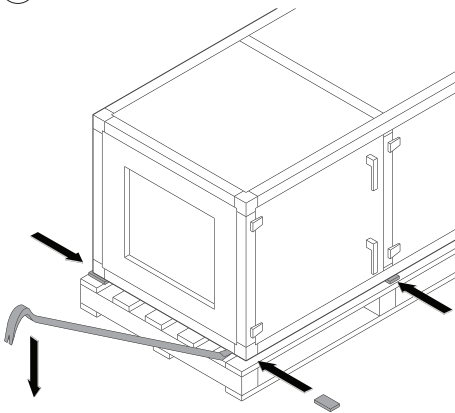


- Air handling units are heavy, therefore care must be taken during lifting, carrying or moving operations. Use personal protection equipment, do not stand under a suspended unit or a part thereof.
- Only an employee qualified to operate a forklift truck or crane and familiar with the principles of cargo lifting and safety requirements, must perform unloading or lifting operations.
- It must be ensured that the casing is not crushed or otherwise damaged by straps or ropes during lifting operations. Use of special supporting structures (traverses) is recommended.
- When lifting the unit or section thereof, note that their center of gravity may differ from the geometric center of the load.
- Mounting of separate air handling units in stacks is not allowed unless it's construction design is intended for such installation.
- Before installation AHU must be stored in clean and dry premises in their original packaging. If the unit is installed but not yet in use, all connection openings must be tightly closed and the unit must be additionally protected against environmental influences (dust, rain, cold, etc.).

Mounting of separate ventilation units in stacks is not allowed unless these devices are intended for such installation.

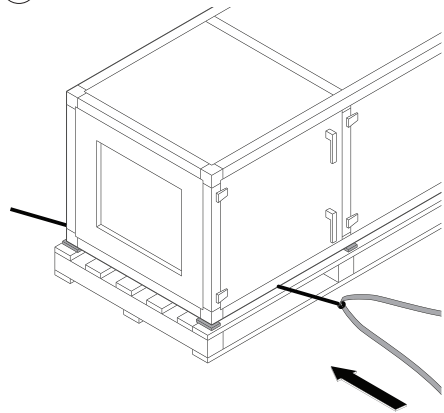
Two-tier sections are placed on top of each other with a crane in the following procedure:

1



Lift corners of the section one after another using a long crowbar to place wooden battens (10–15 mm) between the sections. When sections are in large dimensions, battens shall also be placed under every strut.

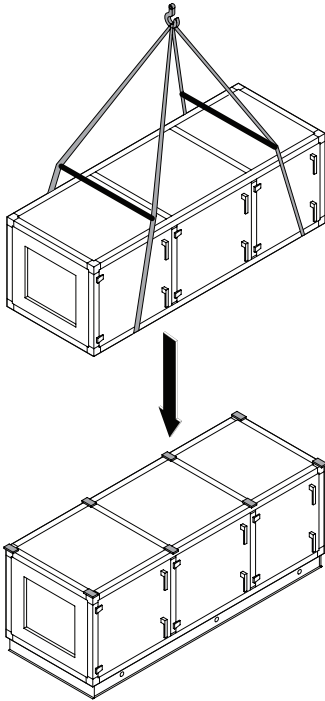
2



Place lifting straps under the section with a long bar or a hook.

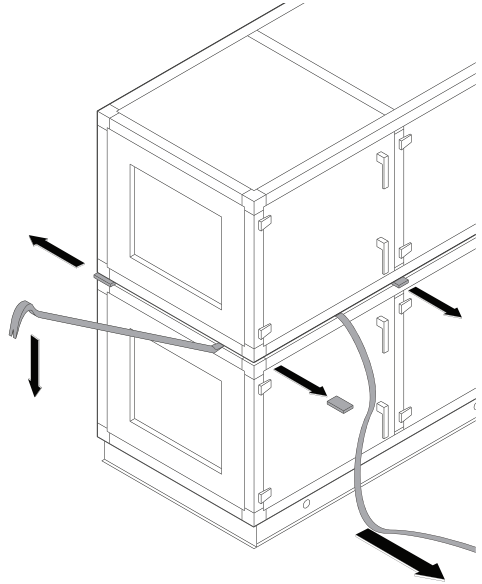


3



Place wooden battens on upper corners and struts of the first-tier section and then lift the second-tier section on top of it with a crane. Observe all lifting rules and ensure that straps do not slip or move when using a crane for lifting operations. Lifting traverses are recommended.

4



Once sections are placed on top of each other, pull out the straps. Lift corners with a long crowbar to remove inserted battens.

## 3. MECHANICAL INSTALLATION

### 3.1. Requirements for Mounting Location and Installation Base

KLASIK air handling units are designed for ventilation of medium or large commercial or industrial premises (e.g., stores, offices, hotels, etc.) where standard air temperature and humidity is maintained. These units are not intended for transporting solid particles within air flows. Standard equipment air handling units are intended for indoor installation; and with additional accessories, these units may be mounted outdoors. Air handling units are designed for ambient temperatures from -30°C to +40°C.



- **KLASIK units are not intended for operation in areas with potentially explosive atmospheres. Air handling units are not designed for ventilation and dehumidification of wet areas (pools, saunas, car washes, etc.).**
- **If the AHU is installed in a room with high humidity level, condensate may form on the walls of the unit at low outdoor temperatures.**

An air handling unit must be mounted on a relatively large and sturdy base, based on the weight of the unit and in accordance with building regulations.

If the device is not equipped with height adjustable feet, it must be installed on a flat base. The base can be made from poured reinforced concrete or from pre-fabricated metal structures. Vibration dampening gaskets must be installed between the unit and its installation base. When the unit is not equipped with an installation frame or height adjustable feet, it should be fixed to the base using metal angle brackets and rubber vibration dampening gaskets. Units mounted to ceilings or other special structures must be fixed using threaded bars and vibration dampening holders. During installation, both suspended and stationary units must be levelled in respect to the horizon. Deviations shall not exceed 0,3 mm for 1m in the longitudinal direction and 0,5 mm for 1m in the transverse direction.



**If ventilation unit is not intended to be installed right away, it must be stored in dry and clean environment, in the original packaging. If unit is installed, but will not be used yet, all duct connection openings must be closed and additional protection from the surrounding conditions (dust, rain, cold, etc.) must be made.**

### 3.2. Inspection Area

Based on its type, an air handling unit may be installed indoors or outdoors. When selecting an installation or mounting location, you must foresee sufficient and security compliant access space for repair and maintenance operations. The unit must be installed in a way to allow partial or full disassembly and removal of assemblies out of the sections, if needed (e.g., in case of complex repairs).

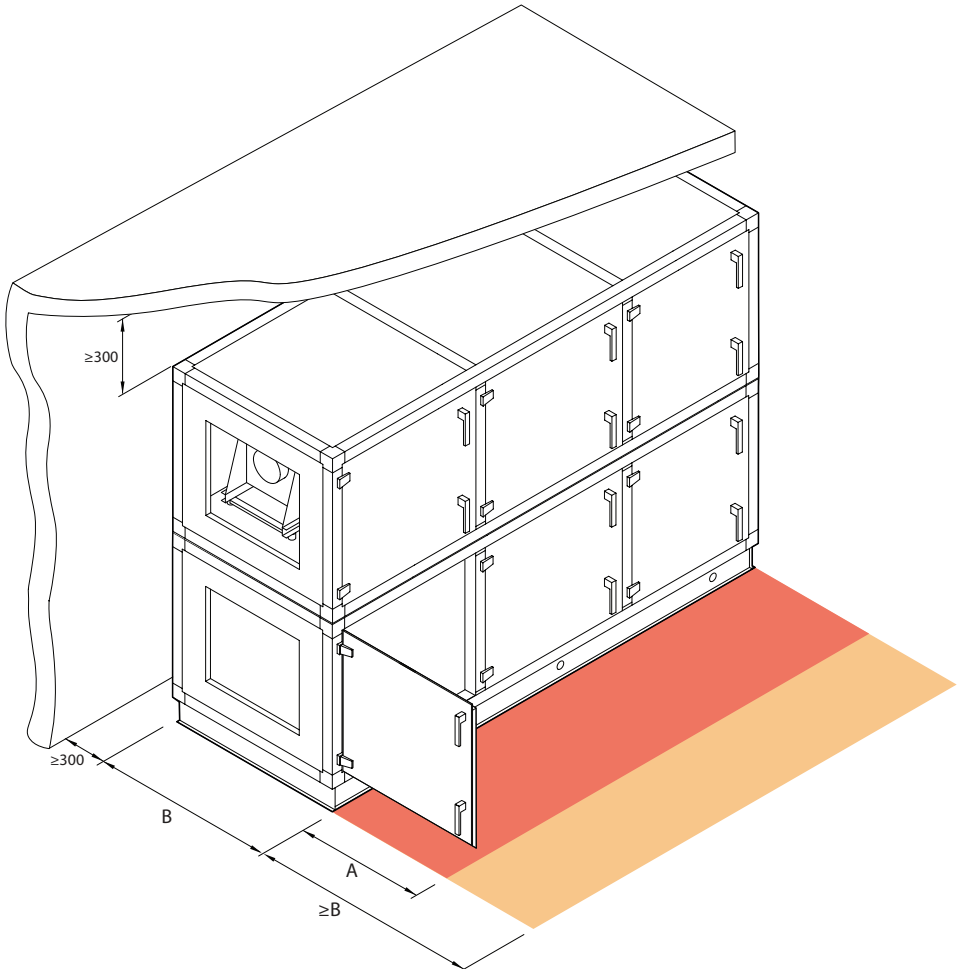


Fig. 14. Device inspection area

Minimum service area A defines an area which must be free of any stand-alone or immovable devices, equipment, partitions, structure or furniture. This area is sufficient for performing service and filter replacement works. For repair and replacement of components (e.g., removal of rotary heat exchangers), access area equal to the width of the device B shall be ensured in front of the device. Additionally, for easier installation and maintenance, it is recommended to leave at least 300 mm behind and on top of the unit where possible.

Unit size	Unit type							
	R		CF		RA		S	
	A	B	A	B	A	B	A	B
1	800	1055	800	1055	800	1055	800	1055
2	800	1195	800	1195	800	1195	800	1195
3	800	1345	800	1345	800	1345	800	1345
4	900	1545	900	1545	900	1545	900	1545
5	900	1785	900	1785	900	1785	900	1785
6	900	1945	900	1945	900	1945	900	1945
7	1000	2180	1000	2180	1000	2180	1000	2180
8	1150	2350	1150	2350	1150	2350	1150	2350
9	1150	2650	1150	2660	1150	2350	1150	2350
10	1350	2850	1350	2660	1350	2350	1350	2350
11	1350	3120	1350	2960	1350	2590	1350	2590
12	1500	3220	1500	3350	1500	2890	1500	2890

### 3.3. Door Handles and Hinges

KLASIK door handles are designed in such a way that the unit door does not swing open due to the pressure accumulated inside the unit and does not injure the person opening the door. By pressing the handle, the door slightly opens and locks to release air pressure inside the unit. Return the handle to its original position to fully open the door.

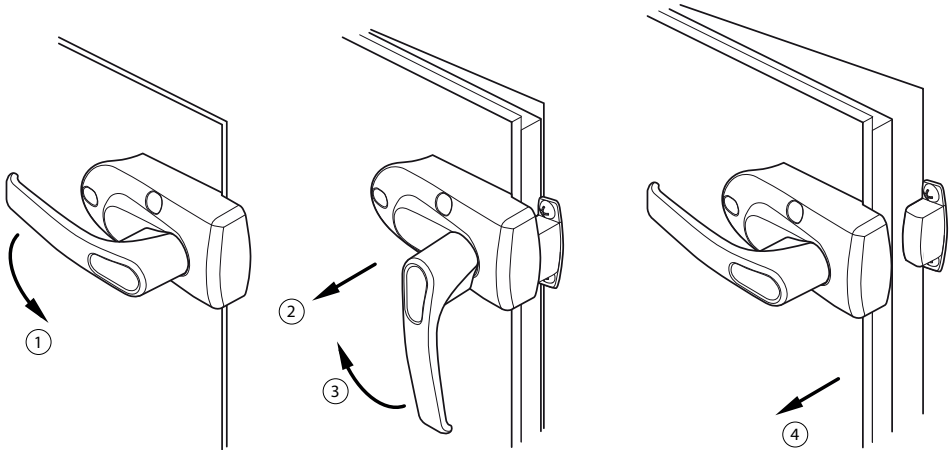


Fig. 15. Opening the door

As large unit sections may be difficult to connect properly on site and the unit door may warp, it is necessary to adjust the hinges. Loosen the lock screw to raise/lower the door by a few millimetres.

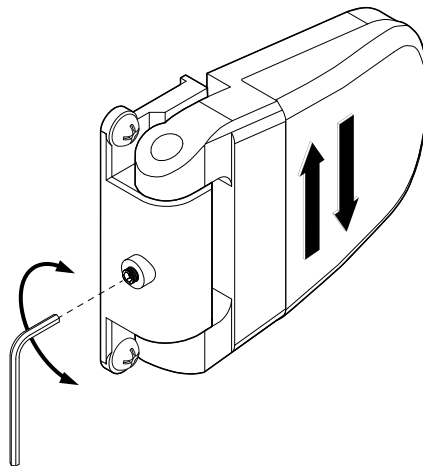
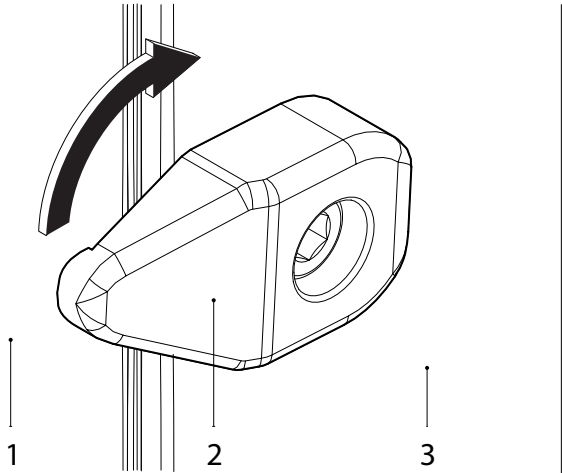


Fig. 16. Adjusting the hinges

Some panels of the unit do not have handles. They are fixed with special screws or knobs that need to be turned to remove the panel.



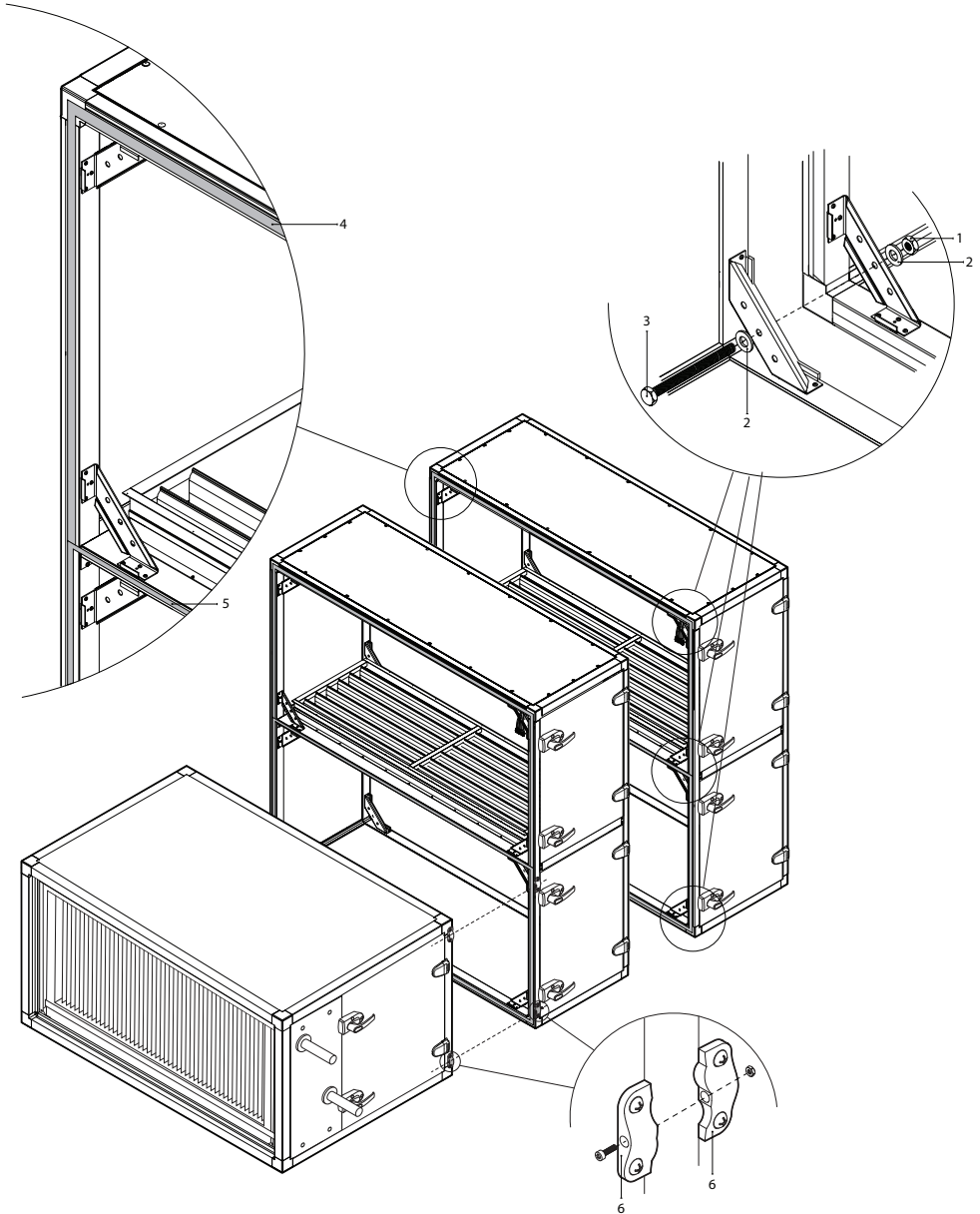
**Fig. 17.** Panel fixing knob  
1 - removable panel, 2 - fixing knob, 3 - unit frame

### 3.4. Connection of Sections

Connect connecting cables and wires of the sections (see Chapter “Electrical Installation”) before fastening sections of an air handling unit.



- If, for any reason, sections of the unit were disassembled, before installation at it's final location, airtightness of the unit may differ from the data provided in documentation, unless the unit is assembled by personnel trained by the manufacturer.
- Sealing gaskets must be fitted between the sections (supplied with the unit).
- For outdoor installation, joints between the sections must be additionally sealed with silicone or other sealant.
- Drilling and using self-tapping screws on the unit casing is prohibited (where it is not provided by the construction), since cables or tubes inside of the casing may be damaged.
- Adjust the position of the rotary wheel in relation to the section housing before connecting all the sections (see Appendix No.1).
- On units for hygienic or medical applications, all internal connections must be additionally sealed with neutral sealant corresponding to sanitary requirements.



**Fig. 18.** External connection and sealing of sections  
 1 – nut M10, 2 – washer, 3 – screw M10, 4 – adhesive gasket,  
 5 – gasket on a shelf between different air flows, 6 – external tightening elements

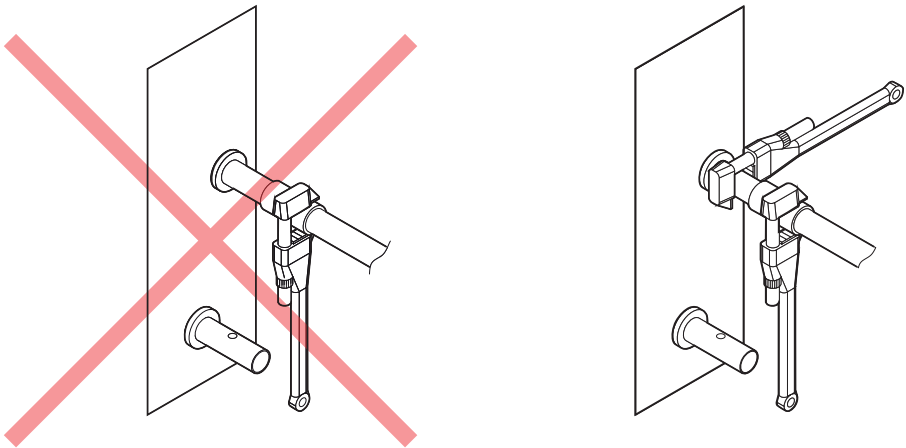
Depending on the unit size and purpose of sections thereof, separate sections may be interconnected with external tightening elements or internal tightening brackets, using supplied screws and/or spacers. Sealing gaskets must be attached to joints before joining the sections (supplied with the unit). Gaskets are installed around the entire perimeter of the section as well as on a shelf which separates different air flows. Screws must be tightened so that the gasket is fully compressed and distance between the sections does not exceed 2–3 mm. If the unit is ordered with an installation frame, additionally sections shall be tightened through the designated holes in the installation frame (insert internal section connection screws first, before tightening installation frame).

### 3.5. Installation of Heating/Cooling Devices

- Pipes of water heaters/coolers are connected to a water mixing unit (PPU) that supplies hot/cold water from the building's water system.
- Pipes of liquid-coupled heat exchangers are connected to a PPU-LCHX mixing unit, that circulates thermal liquid and controls recuperation.
- Coils of direct evaporation (DX) coolers/heaters are factory-filled with nitrogen gas. Before connecting the coil to a refrigerant system, nitrogen gas is discharged through a valve which is then cut off and connections are soldered to a pipeline.
- Coils for water or DX coolers are fitted with condensate trays to which a siphon and drainage piping must be connected (see Chapter "Connection of a Condensate Drain").
- Electrical heater sections require a separate power supply.



**All connections to the heating or cooling system piping and mains must be performed by a qualified specialist.**



**Fig. 19.** Connection of sleeves



When connecting sleeves of liquid coupled heat exchanger or water heaters/coolers, use two pipe wrenches to secure sleeves, otherwise they will be damaged. If water is used in the heater, for frost protection return water temperature sensor (B5) must be installed on the return water pipe as close to the heater as possible. It can be screwed<sup>1</sup> into a special opening or fixed with a strap on the pipe. Fix the sensor in a way that its metal part has good contact with a surface of the pipe. The sensor must be thermally insulated so that the room temperature does not distort water temperature measurements.

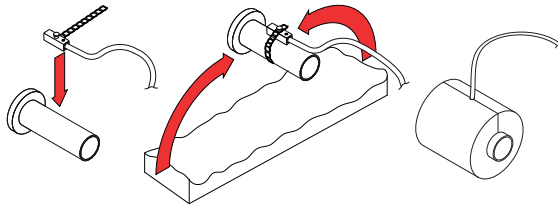


Fig. 20. Installation of a surface-mounted return water temperature sensor<sup>2</sup>

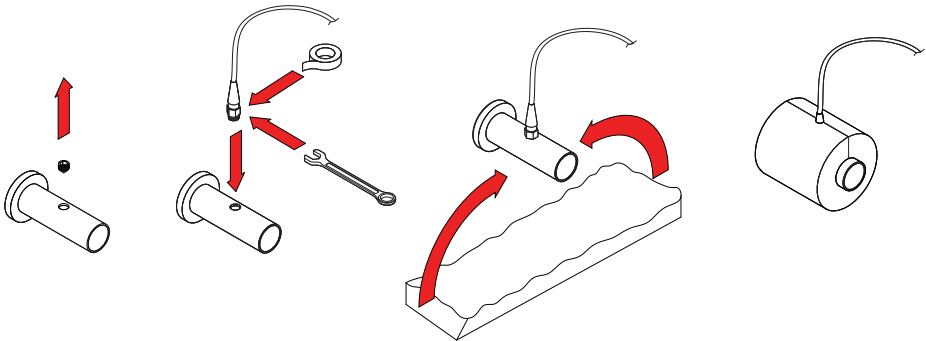


Fig. 21. Installation of a return water temperature sensor with thread<sup>3</sup>



When operating air handling unit in temperatures lower than 0°C, it is necessary to use water-glycol mixture as a heat carrier or to maintain a return water temperature of at least 25°C.



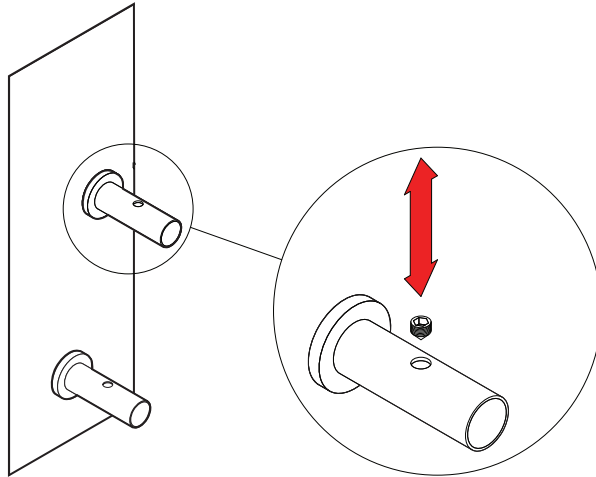
Pipework package<sup>4</sup> must include circulation pump, which circulates heating/cooling medium through the coil (smaller circuit) and 3-way mixing valve with modulated actuator. In cases if 2-way valve is used, additionally it must be installed non-return valves to ensure continuous circulation around smaller circuit. PPU must be installed as close to the water coil as possible.

<sup>1</sup> Depending on the order.

<sup>2</sup> Depending on the order.

<sup>3</sup> Depending on the order.

<sup>4</sup> It is recommended to use PPU made by Komfovent.



**Fig. 22.** Air release from water or liquid-coupled heat exchangers

Water heater/cooler or liquid-coupled heat exchanger coil connections have a screw that can be used for air release from the system or the threaded return water temperature sensor. Do not over-tighten this screw if used (tightening force 5Nm), since it can lead to pipe damage and leakage.

### 3.6. Connection of a Condensate Drain

Operation of units with counter-flow plate heat exchangers, liquid coupled heat exchangers or cooling devices causes condensation, which accumulates in specially designed condensate trays. Condensate is removed from condensate trays via drainage pipes, therefore a condensate drainage system must be connected. Drainage piping must be at least 40 mm in diameter, mounted with a slope, without narrowing sections or loops preventing water from draining. If such drainage piping is installed outdoors or in unheated premises, it must be adequately insulated or equipped with a heating cable to prevent water from freezing during winter. Drainage piping is connected to the unit with a siphon. Due to positive or negative air pressure in the air handling unit, water cannot drain out of the condensate collection tray by itself. Therefore, it is necessary to connect a proper height siphon or a siphon with a one-way valve to the drain pipe.

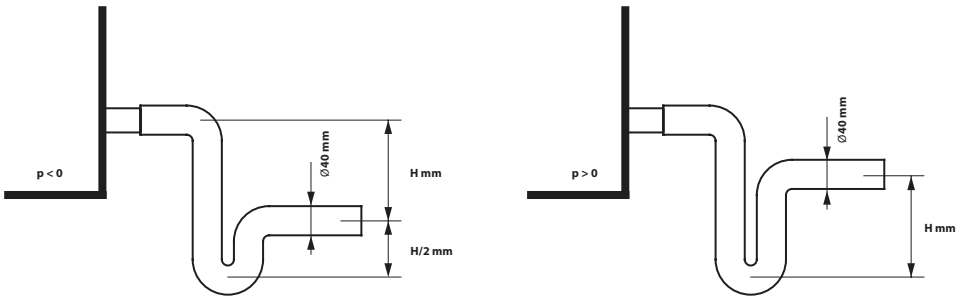


Fig. 23. Installation of a siphon without a one-way valve

Height  $H$  of a siphon without a one-way valve is selected according to static pressure  $p$  inside the air handling unit:

$$H [mm] = 25 + p [mm H_2O] = 25 + 0.1 \times p [Pa]$$

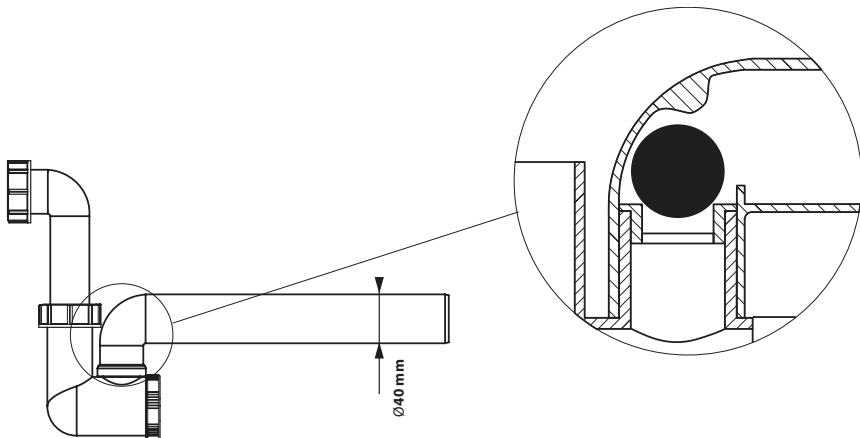


Fig. 24. Example of a siphon with a one-way valve



- Each drain outlet of the drip pans must be equipped with a separate siphon.
- On units for hygienic or medical applications, all drainage siphons must be with one-way valve, for contamination prevention.
- Do not interconnect drainage pipes from separate drip pans together, since pressure difference inside of the unit may prevent removal of the condensate.
- Any drainage system cannot be directly connected to the common waste water system in order to protect supply air from contamination with bacteria and odours.

Condensate from the air handling unit drainage system shall be collected into a separate container or should be lead to a sewage grille without any direct contact: do not connect drain directly to sewer pipe and do not immerse it into water. Condensate collection location must be easily accessible for cleaning and disinfection.

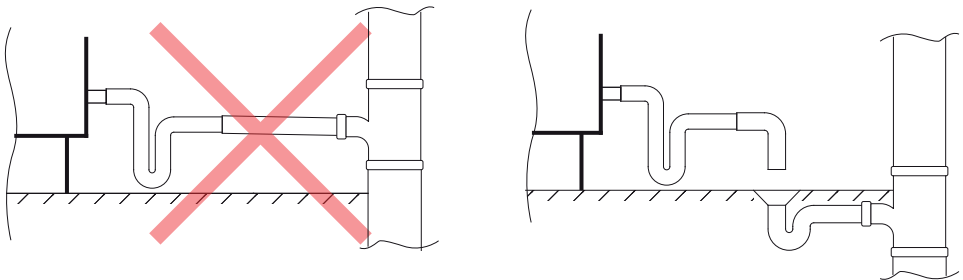


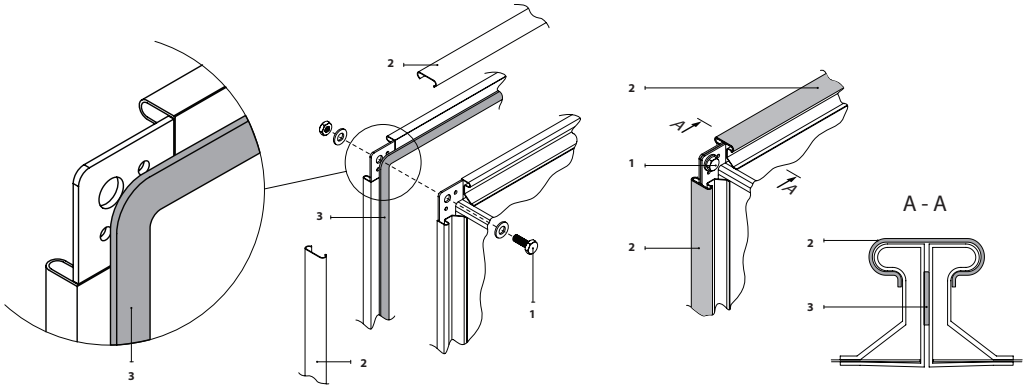
Fig. 25. Condensate drain connection to sewer system

### 3.7. Connection to Air Ducts



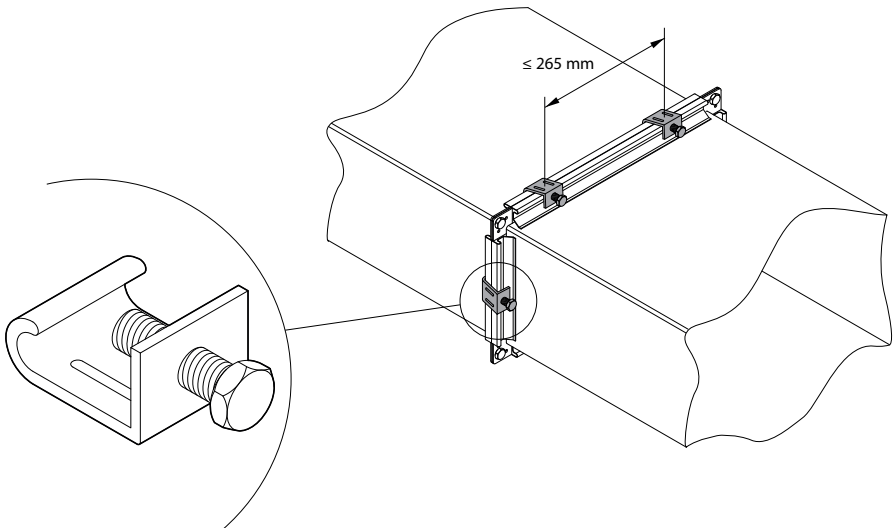
- Ducts and air closing dampers connecting the unit to the exterior of the building must be insulated (insulation thickness 50–100 mm) to prevent condensation on cold surfaces.
- Air intake and exhaust ducts must be fitted with air shut-off dampers (electric with actuators) to protect the unit from exposure to climatic conditions when the unit is switched off.
- In order to minimise AHU generated noise and noise transferring through the ducts into ventilated areas, sound suppressors (silencers) must be connected to the unit.
- Air duct system elements must have separate brackets and must be mounted in a way that their weight is not shifted to the unit casing.

Air ducts shall be connected to flexible unit connections, flanges or air dampers. Depending on the AHU size, L-20, L-30 or L-40 flanges shall be used. Special adhesive gasket must be attached to flanges for airtightness of air ducts. We recommend installing a solid gasket, i.e. do not cut it to smaller pieces. Make sure that the gasket does not cover fastening holes in the corners and is not damaged when fastening screws. Flanges in the corners are fastened with M8x20 screws and a C profile is pressed on edges to connect the flanges.



**Fig. 26.** Example for fastening and sealing of a flange ductwork connection  
 1 – screw, 2 – C profile for connection of flanges, 3 – adhesive gasket

For rectangular ducts where opening sides are longer than 500 mm, it is recommended to use universal clamp connectors instead of C profile to ensure better air tightness. Clamp connectors should be spaced evenly at intervals of no more than 265 mm.



**Fig. 27.** Duct connection example using universal clamp connectors

Air closing damper profile dimensions are the same as those of L-20 flange (for all AHU sizes), thus when mounting additional parts (ducts, flexible connectors, duct heaters/coolers, silencers and etc.) directly to the air damper, they should also have an L-20 flange connection for easier installation.

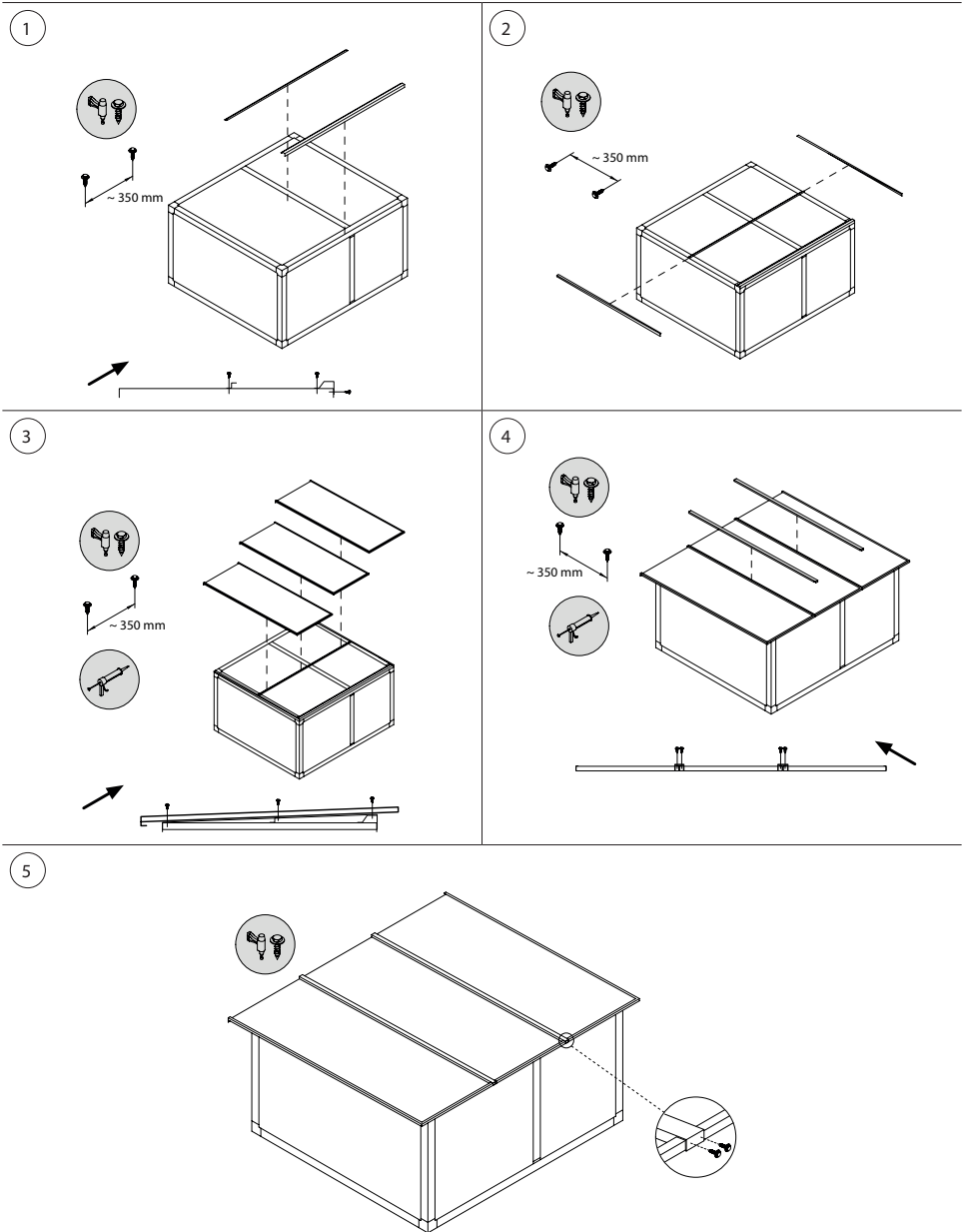
### 3.8. Outdoor Units

KLASIK air handling units for outdoor installation must be additionally protected against environmental effects by installing a protective roof and exhaust air hoods. Units shall be mounted on an installation frame which is attached to an installation base. Ventilation devices, when possible, should be installed near the walls for protection against wind loads. For outdoor installation, units with drainage pipes must be additionally protected against freezing, for example, with electric heating cables for drainage pipes. Air dampers with electric actuators must be protected against environmental influences with special insulated covers or other double shell insulation structures. In such case the ducts must be connected to a flange of the insulated cover and not directly to the air damper. If the unit was ordered for outdoor installation, each section of the unit will be fitted with a protective roof. Separately ordered protective roof shall be installed once the unit is fully assembled.

Connections of units for outdoor installation must be additionally sealed (sealant not included).



- **If the outdoor unit will be switched off during the cold season, supply and extract air ducts (on the indoor side) must be fitted with additional air shut-off dampers. These should prevent warm indoor air from circulating inside the unit when it is stopped to avoid condensation, which may be detrimental to electronic components.**
- **Outdoor installation of air handling units with vertical duct connections is prohibited.**



**Fig. 28.** Installation of a separately ordered protective roof for KLASIK 1-7 size<sup>1</sup>

<sup>1</sup> Part count and measurements may differ depending on the unit type or project requirements.

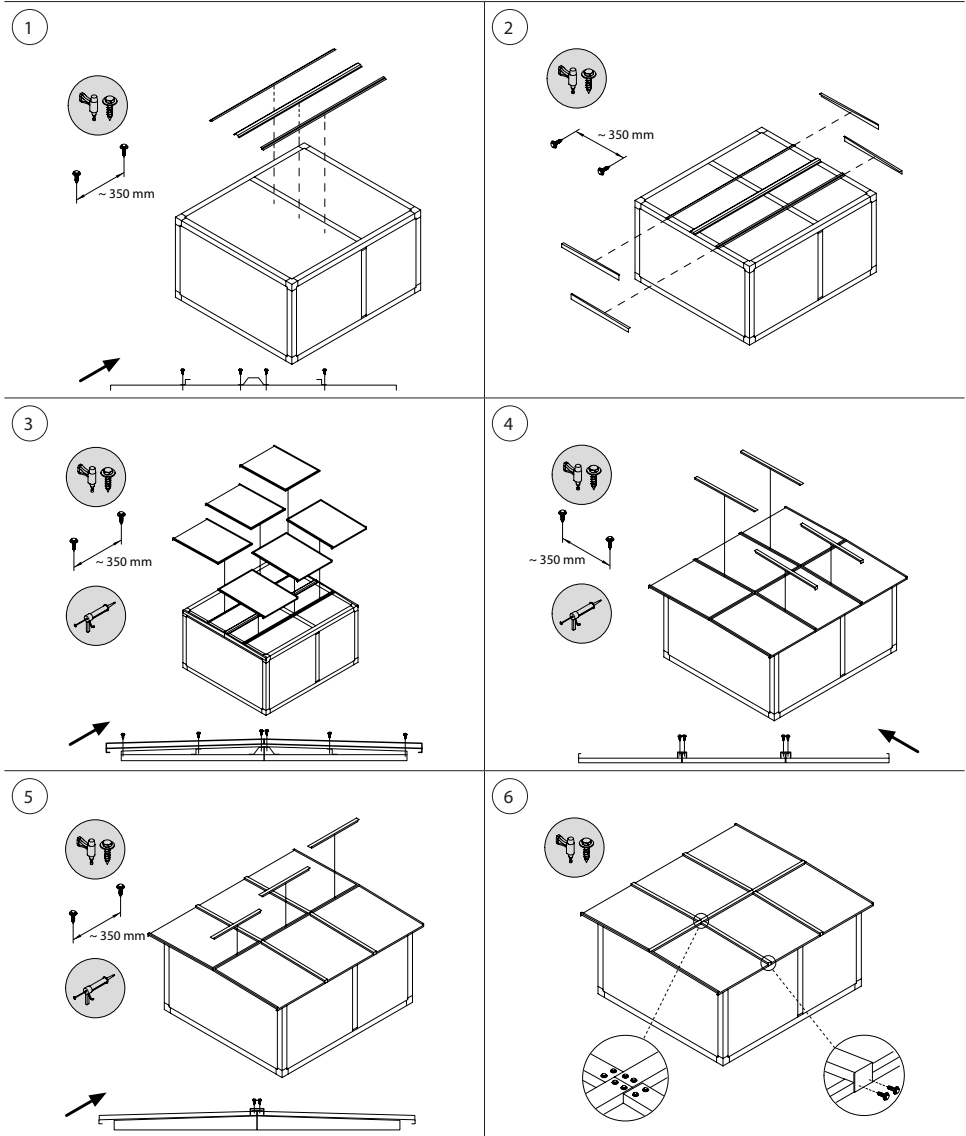


Fig. 29. Installation of a separately ordered protective roof for KLASIK 8-14 size<sup>1</sup>

<sup>1</sup> Part count and measurements may differ depending on the unit type or project requirements.



## 4. ELECTRICAL INSTALLATION

Only qualified professionals may perform electrical installation works in accordance with the manufacturer's instructions and applicable legal acts and safety requirements. Before installation of any electrical components:



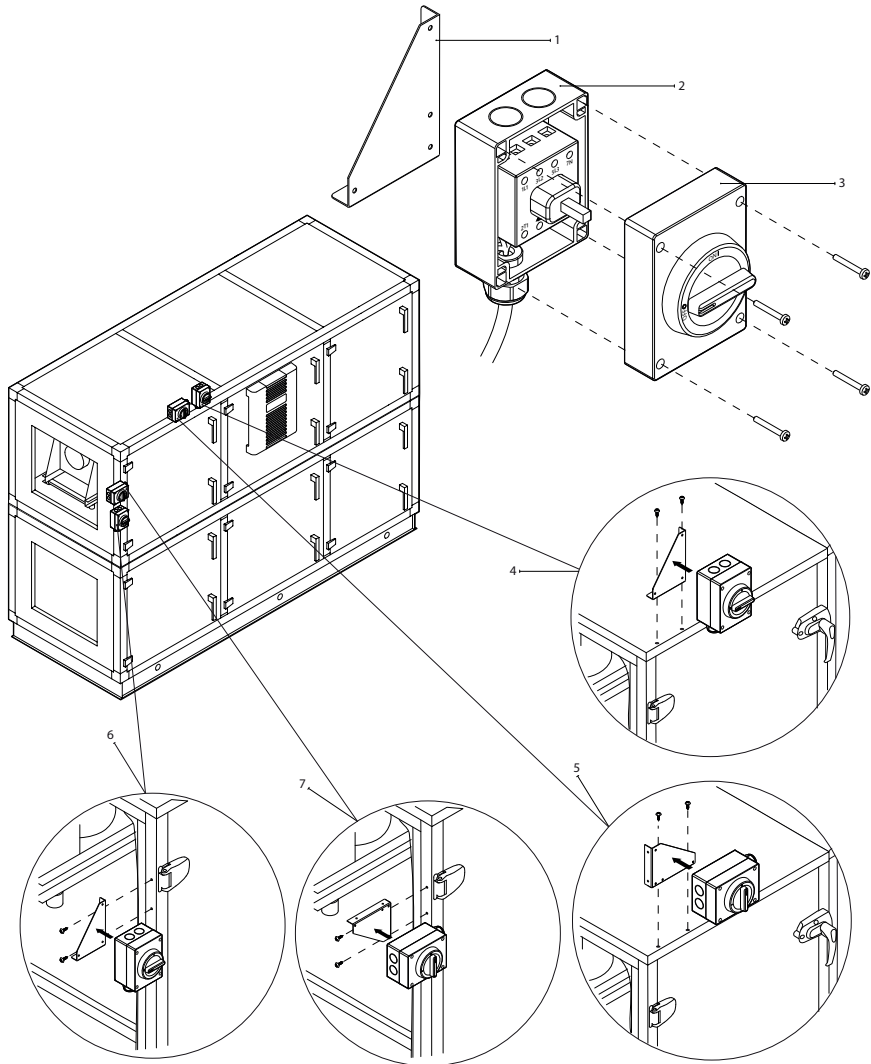
- Make sure the unit is unplugged from the mains.
- If the unit has been standing in an unheated room for a long time, make sure there is no condensation inside and check if contacts and electronic parts of the connectors are not damaged by moisture.
- Inspect the power cable and other wiring for damage in insulation.
- Locate the wiring diagram for your unit according to the unit type.

### 4.1. Requirements for Electrical Connection



- Connect the unit only to a proper power outlet with protective earthing. Earthing must be installed according to the EN61557, BS 7671 requirements.
- It is recommended to connect AHU to the mains via automatic circuit breaker with 300 mA current leakage protection (type B or B+).
- Control cables should be installed at least 20 cm away from power cables to reduce the possibility of electrical interference.
- All external electrical elements must be connected strictly according to the wiring diagram of the unit.
- Do not disconnect the connectors by pulling wires or cables.

Air handling units designed for 400 VAC, 50 Hz supply voltage, connected through the main circuit breaker (QS1 in wiring diagrams). The main circuit breaker comes with a universal bracket that allows fixing it on the top or side of the AHU.



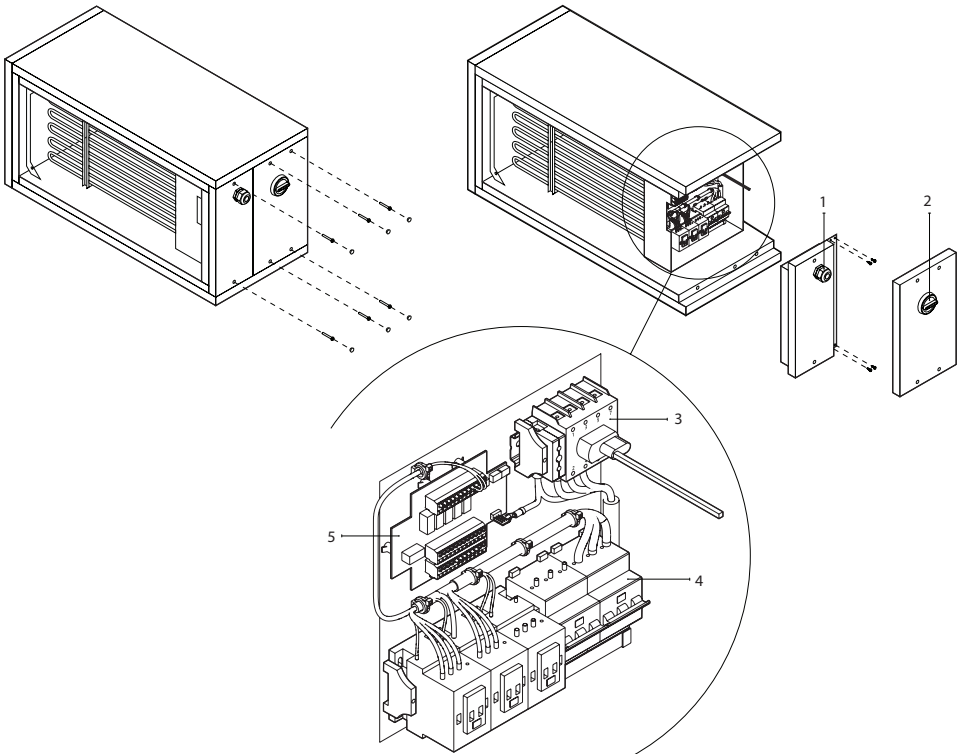
**Fig. 30.** Main circuit breaker and its mounting examples

- 1 – universal bracket, 2 – circuit breaker, 3 – cover of the breaker, 4 – mounting on top of AHU vertically,  
 5 – mounting on top of AHU horizontally, 6 – mounting on the side of AHU vertically,  
 7 – mounting on the side of AHU horizontally



**If circuit breaker bracket is used, it must be mounted on the edge of the unit casing, otherwise self-tapping screws may damage wires or tubing that is routed inside.**

Units fitted with an additional electric heater section will be equipped with a separate main circuit breaker inside the section.



**Fig. 31.** Main circuit breaker inside an electric heater section

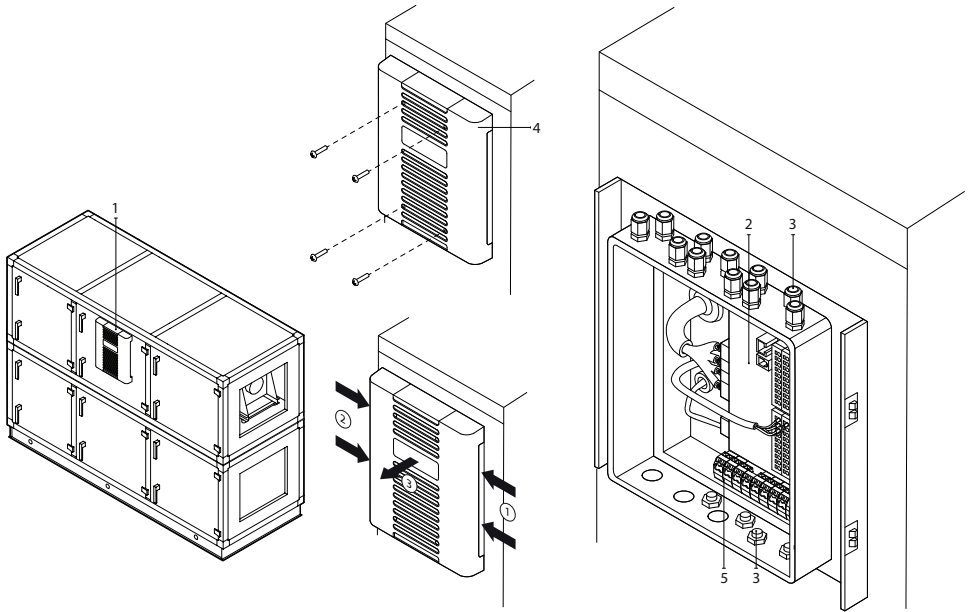
- 1 – lead-in cable grommet, 2 – main circuit breaker handle, 3 – main circuit breaker, 4 – automatic switch, 5 – electronic heater control board

Lead-in cable diameter depends on a maximum current specified in the technical data print-out of the specific unit.

Current, A	Cable type
15	5 × 1,5 mm <sup>2</sup> (Cu)
21	5 × 2,5 mm <sup>2</sup> (Cu)
27	5 × 4,0 mm <sup>2</sup> (Cu)
34	5 × 6,0 mm <sup>2</sup> (Cu)
50	5 × 10,0 mm <sup>2</sup> (Cu)
70	5 × 16,0 mm <sup>2</sup> (Cu)
85	5 × 25,0 mm <sup>2</sup> (Cu)
100	5 × 35,0 mm <sup>2</sup> (Cu)
135	5 × 50,0 mm <sup>2</sup> (Cu)

## 4.2. Connection of Electrical Components

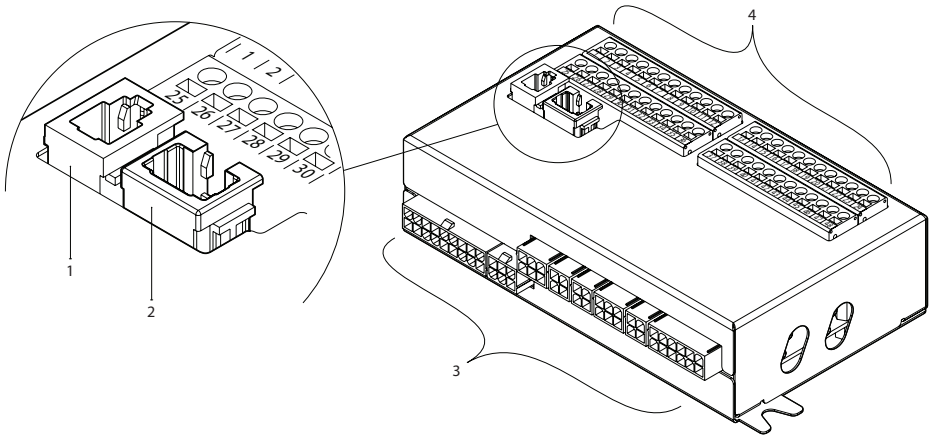
All internal and external devices are connected to the main board of the C5 control panel (RG1 in wiring diagrams) located in the automation box. Automation box is fitted at the front of the unit, top part of the heat exchanger section. Box is airtight and is opened by removing four screws and pressing the four latches on the sides of the box.



**Fig. 32.** Automation box

1 – automation box, 2 – main board of the C5 control panel, 3 – grommets for wires, 4 – Automation box cover, 5 – additional connection terminal block

On complex units where specific electrical solutions or connections are needed, the main board of C5 controller and/or other electronics can be installed in an external or internal metal automation box, custom-fitted for exact needs. Refer to the technical printout and wiring diagrams of the exact unit for additional information.



**Fig. 33.** Main board of the C5 control panel

- 1 – control panel connection, 2 – Intranet or Internet connection, 3 – inner connections of components, 4 – terminals for external components

Terminals for the external elements of the controller board are numbered and are used only to connect external components. These may remain empty if no additional features are required.

INPUTS	B9	Humidity sensor	0..10V	25	1	B	MODBUS RS485 interface	OUTPUT			
			-24V	26	2	A					
			N	27	3	GND					
	B8	Air quality sensor	0..10V	28	4	IN4	External control	INPUTS			
			-24V	29	5	IN3			External stop		
			N	30	6	IN2			Fire alarm system		
	B7	Exhaust air pressure sensor	0..10V	31	7	IN1	C	OVR control			
			-24V	32	8				Common		
			N	33	9						
	B6	Supply air pressure sensor	0..10V	34	10	NTC	Return water temperature sensor	B5			
			-24V	35	11						
			N	36	12	NTC			Supply air temperature sensor	B1	
OUTPUTS	FG1	Air damper actuator	0..10V	37	13	0..10V	Humidifier control	TG3			
			-24V	38	14	GND					
			N	39	15	0..10V					
		Operation	Alarm	Common	Indication	NO	40	16	Cold water mixing valve / DX capacity control	TG2	
						NO	41	17			-24V
						C	42	18			N
	DX	DX3 / Heating	DX2 / Cooling	DX1 / Start	Common	NO	43	19	Heating damper actuator	TG1	
						NO	44	20			0..10V
						NO	45	21			-24V
	INPUT	Water pump/ coil alarm				DIN	47	23	Water pump for cooling 230V AC, 1A	S2	
						GND	48	24			N
											L

**Fig. 34.** Connection terminals for external components on the C5 main board



Total power of all external devices with 24 V supply voltage shall not exceed 25 W.

**Modbus RS485 (1-3)** – data cable connection for controlling the unit from a building management system via Modbus RTU protocol.

**External control (4–8)** – terminals for controlling specific functions of the unit via external contacts which are connected to a common terminal 8. These include thermostats, switches, motion sensors and other devices with normally open or closed contacts. Activated functions will operate as long as those contacts are connected.

- **Terminal 4** is used for activating recirculation (if a recirculation damper is ordered, controlled by an external contact) or switching between heating and cooling modes when a combined water heater/cooler coil is fitted (when terminals are connected, the water valve actuator and pump will be controlled by a cooling signal. For example, a thermostat can be connected here to close terminals when cold water circulates in the system).
- Closing contacts **5** and **8** will stop the unit.
- Fire alarm requires a normally closed contact (NC), therefore, a jumper is connected between **terminals 6 and 8**, instead of which, building fire system can be connected. When the contact is disconnected, the unit stops, fans speed up (according to the order) and a fire alarm message is displayed.
- **Terminal 7** activates an “Override” ventilation mode (OVR). This mode has priority over other AHU functions and may be activated even when the unit is stopped (i.e. to start the unit by closing contacts). OVR function settings are set via the control panel or computer. This function is active as long as terminals are closed.

**B5 (9–10)** – when a water heater is installed, this terminal is used for connecting a return water temperature sensor (NTC 10kΩ) which protects against freezing. Also, an additional capillary thermostat<sup>1</sup> (NC contact), if it is mounted on the surface of the water coil, can be connected in series with the return water sensor.

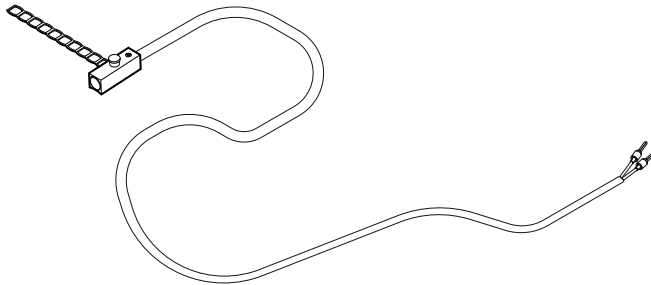
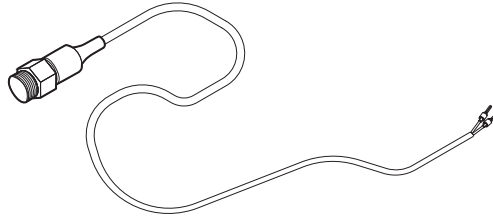


Fig. 35. Surface-mounted return water temperature sensor<sup>2</sup>

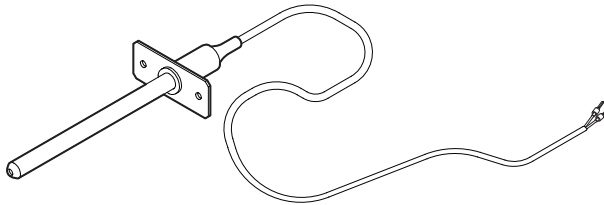
<sup>1</sup> Sold separately.

<sup>2</sup> Depending on the order.



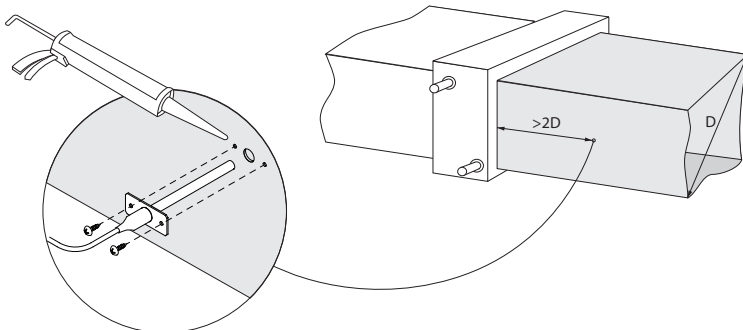
**Fig. 36.** Return water temperature sensor with thread<sup>1</sup>

**B1 (11-12)** – terminal for a supply air temperature sensor (NTC 10k $\Omega$ ) for controlling air temperature.



**Fig. 37.** Supply air temperature sensor

For the most accurate temperature measurement, sensor in a duct must be installed after all heating/cooling devices at least two duct diameters away from the nearest coil.



**Fig. 38.** Installation of a supply air temperature sensor

<sup>1</sup> Depending on the order.

**TG3 (13–14)** – for connecting control signal (0..10 V) of an external humidifier or dehumidifier, if activated. If the humidifier/dehumidifier also needs an additional “Run” signal when AHU is in operation, 40 and 42 terminals can be used for this purpose.

**TG2 (15–17)** – power supply (24 V AC) and control signal (0..10 V) for a water cooler mixing valve actuator. If a DX unit is installed (controlled by a modulated signal), DX unit control signal is connected to these terminals and water cooling is disabled.

**TG1 (18–20)** – power supply (24 V AC) and control signal (0..10 V) for a water heater mixing valve actuator. If a combined water heater/cooler is used, valve actuator will be controlled by a heating or cooling signal (whichever is supplied).

**S2 (21–22)** – 230 V AC supply voltage for a cold water circulation pump, which is used with external water cooler coil and is activated when cooling is needed. Max 1 A.

**S1 (23–24)** – 230 V AC supply voltage for a hot water circulation pump, which is used with external water heater coil and is activated when heating is needed. Max 1 A.

**B8/B9 (25–30)** – terminals for air quality and humidity sensors, which are used for the following functions (see “User Manual”):

- Air quality control (AQC).
- Recirculation control (REC).
- Operation on demand (OOD).
- Humidity control (HUM).

These functions may be controlled via the following type sensors (sensor type may be changed only by an authorised service representative):

- Carbon dioxide CO<sub>2</sub> (default setting) – range 0..2000 ppm.
- Air quality VOC (*Volatile organic compound*) – range 0..100 %.
- Relative humidity RH – range 0..100 % RH.
- Temperature TMP – range 0..50 °C.

**B6/B7 (31–36)** – when a VAV airflow control method is used (see “User Manual”), optional pressure sensors must be installed and connected in the ducts. Follow the manufacturer’s instructions for installation of VAV pressure sensors. Also, these terminals are used for DCV airflow control when a separate 0..10 V signal can be used to adjust the ventilation intensity (see “User Manual”).

**FG1 (37–39)** – terminals used to connect air damper actuators. Also terminals are dedicated for smoke by-pass damper actuator, when optional smoke extraction function is ordered and fans are forced during fire alarm. These terminals may also be used for connecting 24 V AC power supply actuators with or without a spring return.

**Indication (40–42)** – terminals are used when a normally open (NO) contact is necessary for operation status or fault indication. Terminals 40 and 42 are closed when AHU is in operation, thus it can be connected to any external device, which needs such a signal (for example humidifier). Terminals 41 and 42 close when AHU is in an alarm state.

**Cooling control (43–46)** – digital normally open (NO) outputs for controlling direct expansion (DX) coolers/heaters. The purpose of outputs differs depending on the type of DX device control ordered or programmed in the control panel<sup>1</sup>:

- Stepping control of start/stop type DX cooling devices – each of the 3 outputs is activated one after the other, when the power of the previous stage is insufficient, with 5 min. delay.
- Stepping control of start/stop type reversible (cooling/heating) DX devices – DX1 and DX2 outputs are activated one after the other, when the power of the previous stage is insufficient, with 5 min. delay. DX3 output is used for switching DX devices between cooling and heating modes.
- If a DX device is controlled by a modulated signal (0..10 V), digital outputs are used for starting a DX unit and changing operation modes thereof: DX1 – start signal, DX2 – cooling, DX3 – heating. Power control signal for this type of the DX unit is connected to TG2 terminals.

**Water pump/coil alarm (47–48)** – here you can connect signal for indication of water pump faults (if this function is available on the pump); if the pump fails, the air handling unit is stopped.

<sup>1</sup> If the DX device was not predefined in the controller software, these outputs will be inactive.



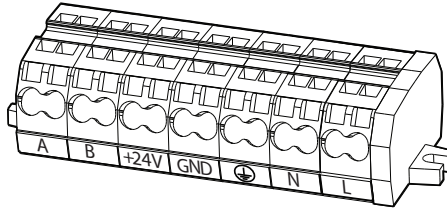


Fig. 39. Additional connection terminal block

**Additional zone connection (A, B, +24V, GND)** – terminals are used for optional additional zone modules, that are used to control duct-mounted heating/cooling devices. For information on how to activate this function and set a desired temperature for each zone see “User manual”.

**230V power output (N, L)** – auxiliary devices that require a 230V power supply (e.g. laptop charger) can be connected here during AHU repair or maintenance.

All wires to be connected to the main board of the control panel shall be pulled through grommets (top or bottom of the automation box). Grommets are fastened to ensure tightness. Depending on whether the wires will be pulled up or down, break a tab at the top or bottom edge of the box cover.

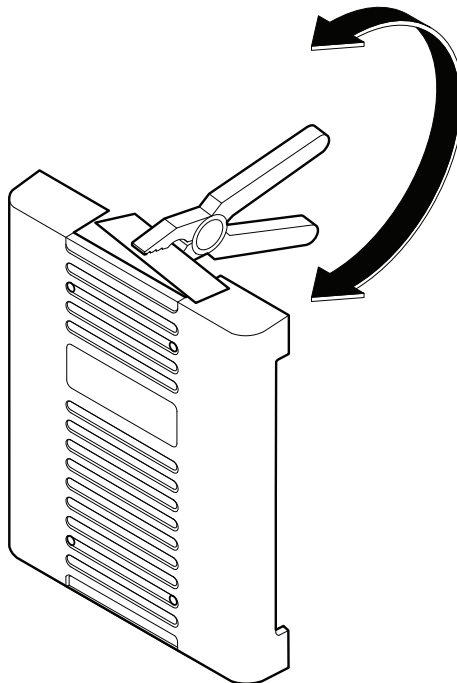
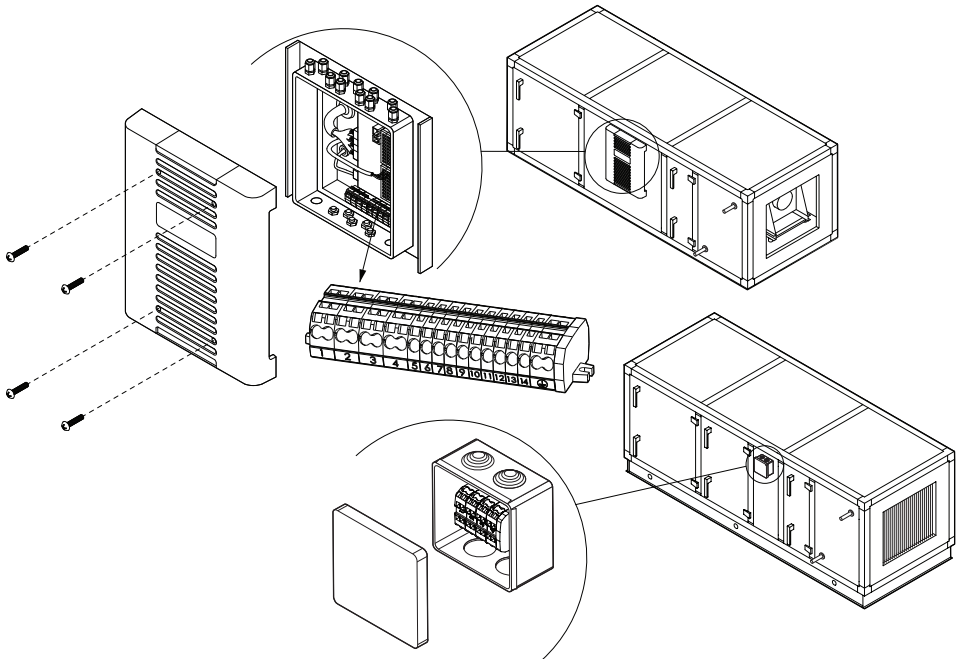


Fig. 40. Automation box cover

### 4.2.1. Connection terminals of KLASIK RA air handling units

KLASIK RA units can be designed as a single (mono-block) unit, or divided into two separate assemblies (for supply and exhaust airflows). If divided, each block will have a separate automation or connection box with terminals inside. The main C5 controller board can be found in the automation box, usually located on the supply air assembly. On the second assembly, it will be just a connection box, without a controller inside. Both blocks will also have a separate main power switch and circuit breakers.



**Fig. 41.** Connection terminals of KLASIK RA air handling units

As the blocks of the air handling unit can be far apart, they can only be connected when the unit is installed in its final mounting position. The terminals in the automation box are used to connect the supply and extract air assemblies to each other, also to connect a circulation pipework unit<sup>1</sup> or a three-way valve and a pump. The terminals of the communication cables are numbered the same way on both blocks of the unit, and the additional connections may vary.

1	A	Communication between supply and extract air blocks + Additional zone module
2	B	
3	+24V	
4	GND	
5	+24V	Frequency inverter of the circulation pump (0..10V) or 3-way valve
6	GND	
7	0..10V	
8	L1	Circulation pump (ON/OFF)
9	L2	
10	L3	
11	N	
12	PE	

Fig. 42. Example of KLASIK RA connection terminal numbering



- Follow the wiring diagram for the specific KLASIK RA unit to ensure which terminals must be connected.
- Do not use external connection terminals of the C5 mainboard for the supply and exhaust air assemblies interconnection.

### 4.3. Control Panel Installation

The control panel must be installed in a room with:

- Ambient temperature – 0..40°C;
- Relative humidity – 20..80 %;
- Guaranteed protection against accidental water drops.

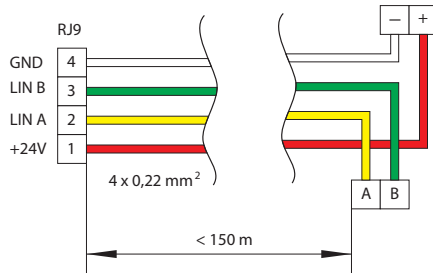
Control panel can be mounted in a concealed mounting box or directly on the wall (screws supplied with the panel). You can also use magnets (on the back surface) to attach the panel to metal surfaces (i.e. on the door of the unit).



**Do not use any other type or size screws but those that are supplied for control panel mounting. Wrong screws may cause damage to a circuit board.**

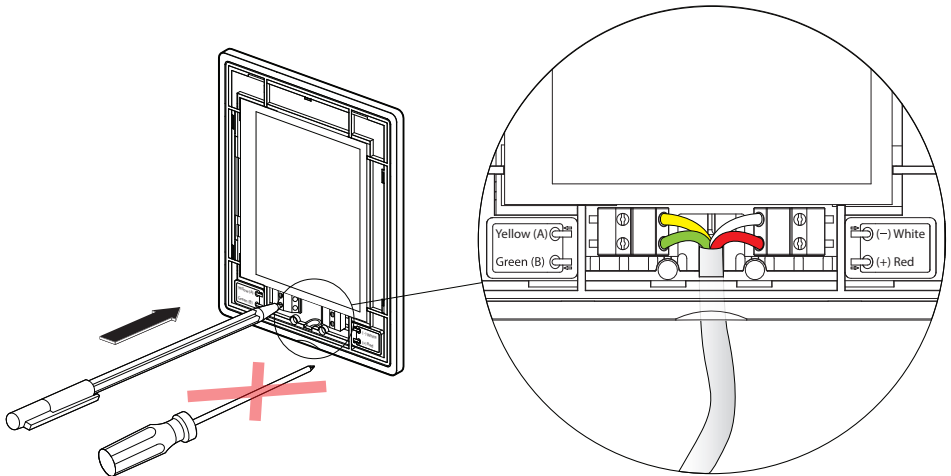
<sup>1</sup> Sold separately. It is recommended to use a pipework package (PPU-LCHX) made by Komfovent.

Control panel is supplied with a 10 m cable. If this cable is too short, you can replace it with a  $4 \times 0,22$  mm cable, up to 150 m long.



**Fig. 43.** Control panel wiring diagram

Control panel cable shall be installed further away from other power supply cables or high voltage electrical equipment (electrical enclosure, electrical water heating boiler, air conditioning unit, etc.). The cable can be pulled through openings in the back or bottom part of the control panel (follow the installation instructions provided with the control panel). Cable to the C5 control board must be connected to a dedicated slot (RJ9 connector; see Fig. 33).



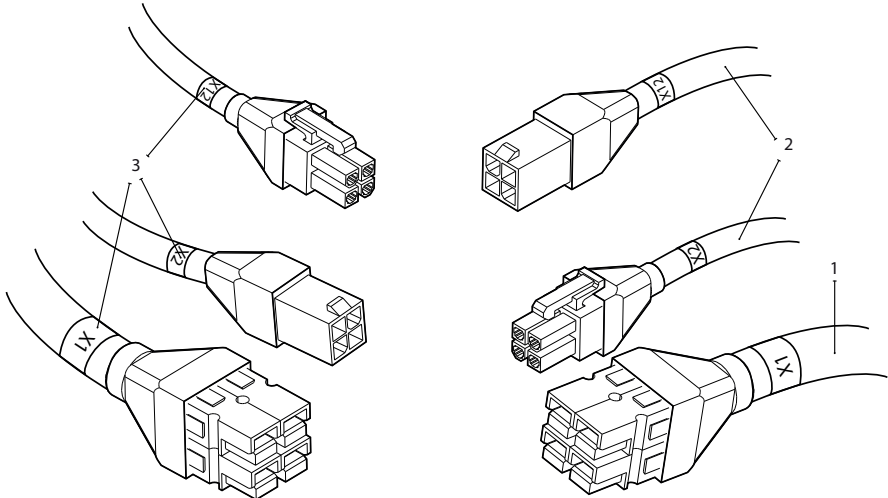
**Fig. 44.** Control panel cable wiring



**Do not use sharp tools for pinning contacts in the control panel (e.g., screwdriver). Please use a pencil or a ballpoint pen.**

## 4.4. Connection of Cables and Wires Between Sections

Before fastening parts of the air handling unit, you shall connect connecting cables and wires of the sections. Cable connectors are labelled with connector numbers; only connect connectors with the same number. Number of cables and connectors in different sections may differ depending on fitted components. If any features or external components are not ordered, there may be some uncoupled connections between the sections. Refer to the wiring diagram of the specific unit to see what connections should be used.

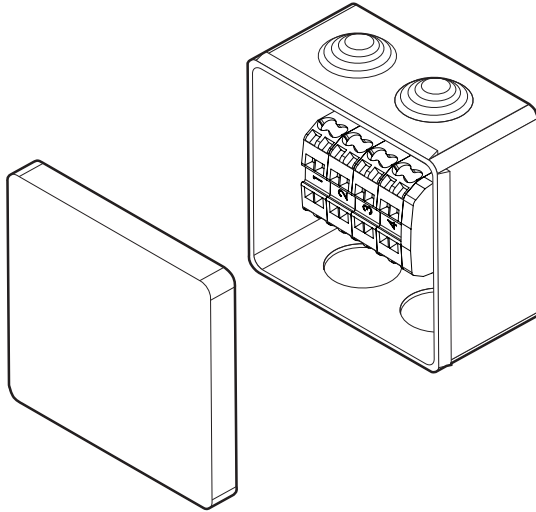


**Fig. 45.** Cable connections between sections

1 – power supply cable, 2 – communication cables between circuit boards 3 – labels with connection numbers

KLASIK RA units can be designed as a single (mono-block) unit, or divided into two separate assemblies (for supply and exhaust airflows). If divided, each block will have a separate automation or connection box with terminals inside (see section "Connection terminals of KLASIK RA air handling units"). Since the supply and exhaust air blocks can be installed far apart, wires and cables to connect them to each other are not included with the unit.

Some components (e.g., damper actuators, humidifier, etc.) do not have separate connectors and must be connected to a terminal block of a junction box (PD in wiring diagrams).



**Fig. 46.** Junction box PD1



Connected wires and cables must be inspected to ensure that they will not accidentally disconnect due to vibrations of the unit or get in contact with moving parts of the unit (fans, valves, rotor wheel). If necessary, use special ties to attach the wires to the unit housing.

## 4.5. Connecting the Unit to the Internal Computer Network or the Internet

Your AHU may be controlled not only with a control panel, but also with a computer or smart phone. For this reason the unit must be connected to the internal computer network or the Internet. In case of a computer, the unit is controlled via a web browser, and in case of a smart phone - via the Komfovent app. Use CAT5 type cable to connect your AHU to the computer network (RJ45 connection; see Fig. 33). The total cable length between the unit and the network router must not exceed 100 metres. By default, the IP address of your air handling unit is **192.168.0.50**, however it can be changed (if necessary) according to the local network parameters. IP address can be found and changed in the control panel.

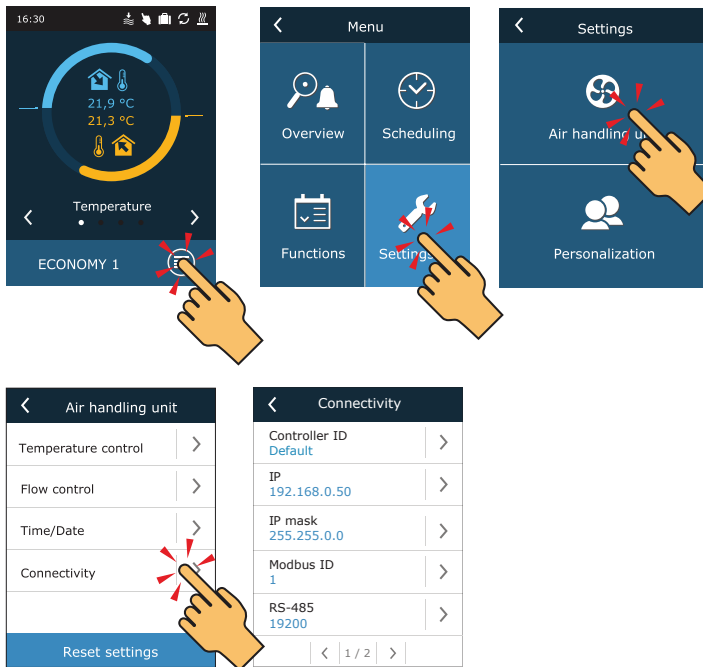
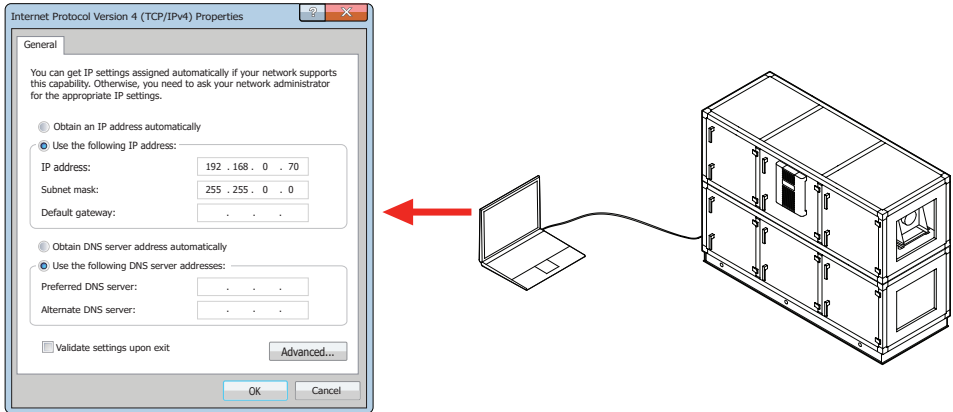


Fig. 47. Viewing and changing the IP address with a control panel

An air handling unit connected to a network router can be controlled by a computer via wireless connection (Wi-Fi). The unit may also be controlled wirelessly in a local network using a smart phone with the Komfovent app. Once the unit is connected to the network router, you should assign a free IP address on the local network.

When connecting your computer directly to the unit, open the network settings and manually assign an IP address, the last number of which would be different from the unit's IP address (for example, if the unit's IP address is 192.168.0.50, assign the address 192.168.0.70 to the computer). Enter the subnet mask: 255.255.0.0.

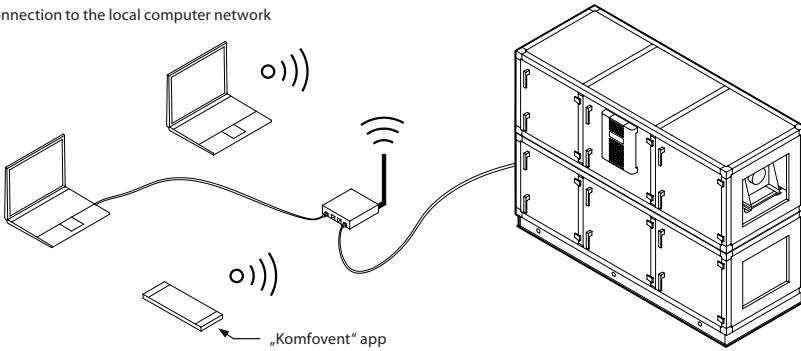


**Fig. 48.** Computer network settings for direct connection to the unit

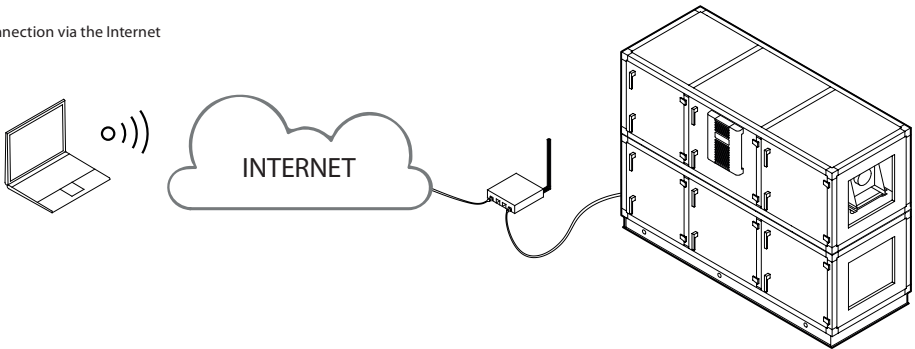
In order to control your AHU over the Internet, connect it to the network router which has access to the Internet. Follow the router manual to configure port forwarding to the unit IP address. Depending on whether you will use your computer or smart phone with the Komfovent app to control your AHU, you will also need to enter a corresponding port number to the router. For control via your computer use the port **80**, and for control via your smart phone use the port **502**. Once a computer or smart phone is connected to the Internet, enter an external router IP address and set port number to your web browser or the Komfovent app to access the AHU user interface (for more information on control with a computer or smart phone see "User Manual").



Connection to the local computer network



Connection via the Internet



**Fig. 49.** Examples for the AHU connection to the Internet or the local network

## 5. COMMISSIONING AND INSPECTION OF THE UNIT

Before switching on the device, check for foreign objects, debris or tools inside the unit. Make sure that air filters are installed and condensate drainage is connected (if necessary), fill the siphon with water. Make sure that the ductwork is free from obstructions such as fully closed diffusers or adjustment valves or blocked external air intake grilles.



- **The operation, maintenance or repair of the air handling unit is prohibited for people (including children) with mental, physical or sensory disabilities, as well as for persons without sufficient experience and knowledge, unless supervised and instructed by the person responsible for their safety in accordance with these instructions.**
- **You may start your AHU only when it is fully installed, ducts and external electrical elements are connected. Do not start the unit without air ducts connected. This may distort air volume measurements required for stable operation of the fans.**
- **Do not use the unit with a temporary electrical power supply as unstable power can damage the electronic components.**

See the KOMFOVENT website for user manuals.

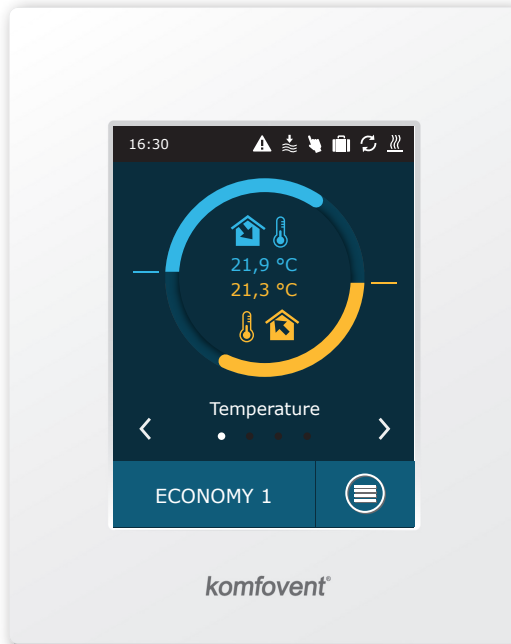
The unit is controlled via a control panel or a computer. The unit is supplied with the following operation modes that may be used immediately after installation or different ventilation settings may be selected.

- **COMFORT 1** – maximum ventilation intensity (100%), desired air temperature – 21°C.
- **COMFORT 2** – average ventilation intensity (50%), desired air temperature – 21°C.
- **ECONOMY 1** – low ventilation intensity (33%), desired air temperature – 20°C.
- **ECONOMY 2** – minimum ventilation intensity (20%), desired air temperature – 19°C.
- **SPECIAL** – maximum ventilation intensity (100%), desired air temperature – 21°C.

This mode may also be used to disable heating/cooling and other functions.

## 5.1. Control panel C5.1<sup>1</sup>

C5.1 is control panel with coloured touch-screen for remote control of your air handling unit. This control panel is designed for indication and changing of various functions and settings of the unit.

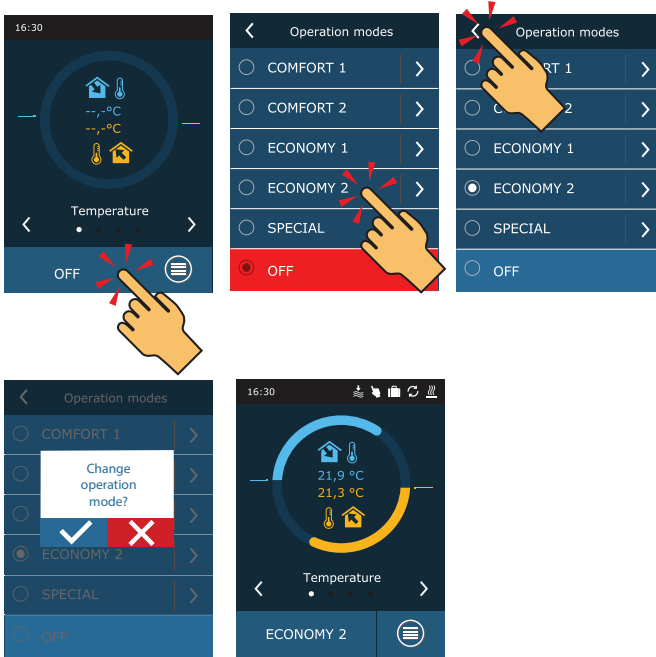


**Fig. 50.** Control panel

If the unit is connected to the mains, the control panel will display a home screen or a screen saver that you can switch off with a single tap.

<sup>1</sup> Sold separately.

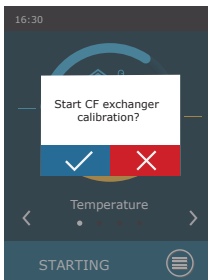
To start an air handling unit or change a ventilation mode:



During the first minute of starting the unit, the unit automation checks the settings, automation components and opens air dampers. Later, a signal is sent to fans and a heat exchanger, and the unit starts operating at a selected ventilation mode.

When starting CF type AHU for the first time, it will be needed to perform heat exchanger calibration, which is used for frost prevention function.

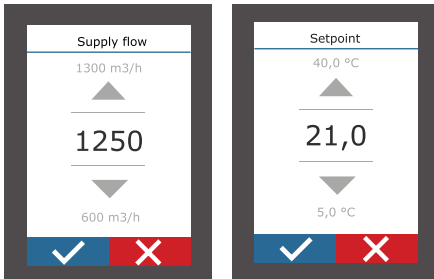
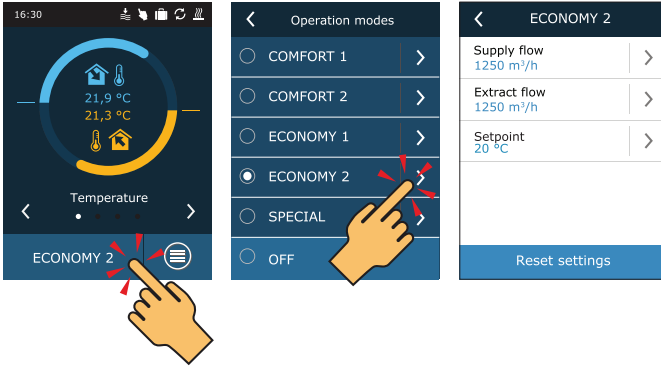
During calibration AHU will operate for about 10 minutes on different ventilation intensities while measuring internal pressure. Thus do not open AHU doors, do not regulate duct system and do not change any settings during CF calibration. If you wish to stop calibration – turn off the unit from the control panel.



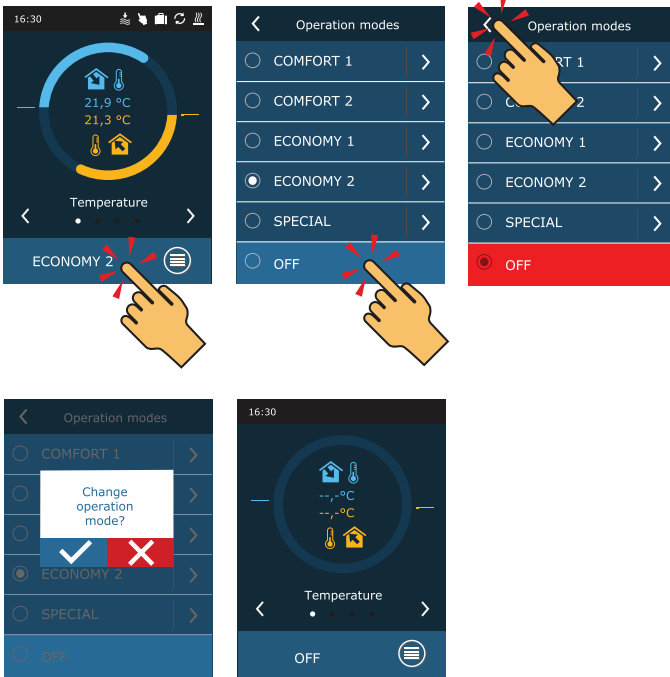


Without calibration, CF heat exchanger may get frozen and will be damaged during low outdoor temperatures.

To change the ventilation mode settings: select a desired mode and set a desired air volume or temperature with the arrows.



To turn of the AHU and return to a home screen:

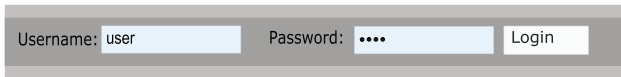


## 5.2. Starting the Unit With a Computer

If the unit was ordered without a control panel or it is not used, you can start it with your computer. In this case the unit is controlled via a web browser. Connect your computer directly to the AHU or to the same computer network as described in Chapter 4.5. Run the Internet browser on the computer and disable the use of all Proxy servers that may block the connection in the settings. In the web browser address bar, enter the IP address of the unit:



Login to the C5 control panel interface in a window that opens: enter the user name **user**, password **user<sup>1</sup>** and press CONNECT.



If you login attempt is successful, "Overview" window is opened.

The screenshot shows the 'Overview' window of the AHU control panel. On the left is a navigation menu with 'Overview' selected. The main area contains a schematic diagram of the AHU system with various sensors and actuators. Below the diagram is a control table.

AHU control	On/Off
Operation mode	Economy2
Active functions	
Alarm status	No alarms

<sup>1</sup> If the password was changed, use the changed password.

To start the unit and change the ventilation mode settings:

1. Press button "Modes".
2. Select a desired ventilation mode from the list.
3. Enter desired air flow and temperature in the selected mode settings.
4. Press "Save" button at the bottom of the screen.

Overview

**Modes** 1

Functions

Alarms/Status

Scheduling

Settings

**▼ OPERATION MODES**

Mode selection	<div style="border: 1px solid #ccc; padding: 2px;">           Comfort1 <span style="float: right;">▼</span>            Comfort2            Economy1  <b>Economy2</b> <span style="float: right;">2</span>            Special            Program         </div>
Supply flow	
Extract flow	
Setpoint	21.0 °C

**Comfort1**

Supply flow	6000 m <sup>3</sup> /h
Extract flow	6000 m <sup>3</sup> /h
Setpoint	21.0 °C

**Comfort2**

Supply flow	6000 m <sup>3</sup> /h
Extract flow	6000 m <sup>3</sup> /h
Setpoint	21.0 °C

**Economy1**

Supply flow	4000 m <sup>3</sup> /h
Extract flow	4000 m <sup>3</sup> /h
Setpoint	20.0 °C

**Economy2**

Supply flow	2400 m <sup>3</sup> /h
Extract flow	2400 m <sup>3</sup> /h <span style="float: right;">3</span>
Setpoint	19.0 °C

**Special**

Supply flow	12000 m <sup>3</sup> /h
Extract flow	12000 m <sup>3</sup> /h
Setpoint	21.0 °C
Heating	<input checked="" type="checkbox"/>
Cooling	<input checked="" type="checkbox"/>
Recirculation	<input checked="" type="checkbox"/>
Humidifying	<input checked="" type="checkbox"/>

**► FLOW CONTROL MODE**

**► TEMPERATURE CONTROL MODE**

Save 4



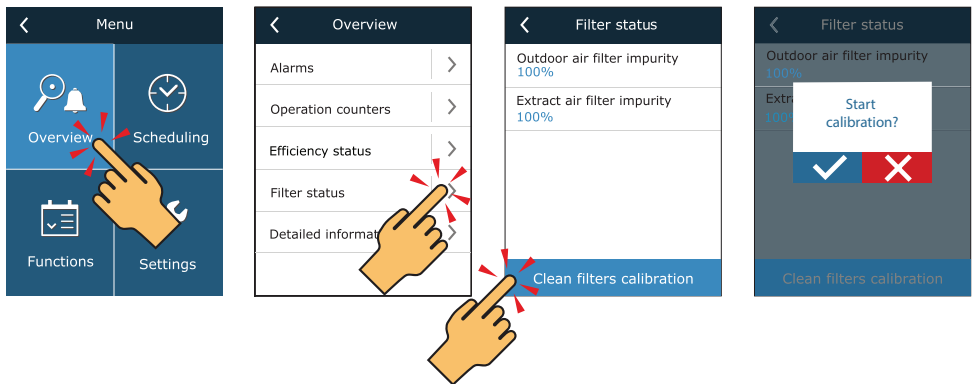
You can stop the unit by pressing ON/OFF button in the “Overview” window.

AHU control	On/Off
Operation mode	Economy2
Active functions	AQC
Alarm status	No alarms

### 5.3. Calibration of Clean Filters

KLASIK control automation continuously monitors filter contamination. Pressure drop of clean filters is preset in the factory. If filters are from another manufacturer or of different filtering class, we recommend performing initial calibration of clean filters before commissioning of the unit. During calibration, the unit will operate at a maximum speed for a few minutes, measure the pressure difference upstream and downstream the filter and automatically set the filter filtration class.

Calibration of clean filters with the control panel:



Calibration of filters with a computer:  
Select Point "Warnings/States":

The screenshot shows a control interface with a left-hand menu and a main content area. The menu items are: Overview, Modes, Functions, Alarms/Status (selected with a mouse cursor and a circled '1'), Scheduling, and Settings. The main content area displays several sections: ▶ ACTUAL ALARMS, ▶ ALARM HISTORY, ▶ OPERATION COUNTERS, ▶ EFFICIENCY STATUS, ▼ FILTER STATUS, ▶ VAV STATUS, and ▶ CONTROLLER STATUS. The 'FILTER STATUS' section is expanded to show a table with three rows: 'Outdoor air filter impurity' with a value of '100 %', 'Extract air filter impurity' with a value of '100 %', and 'Clean filters calibration' with a 'Run' button. A mouse cursor is pointing at the 'Run' button, which is circled with a '2'.

Outdoor air filter impurity	100 %
Extract air filter impurity	100 %
Clean filters calibration	<input type="button" value="Run"/>



If filters ordered with the unit are used (same manufacturer and filtration class), calibration of clean filters is not required.

## 5.4. Quick Inspection

The first time you start your device, make sure that:

Task	Yes	No	Comments
Control panel is working, responds to touch, no error messages			
All air filters are installed			
Air dampers fully open			
There are no unusual noise or vibrations			
Changing the ventilation modes changes the fan speed			
The unit is airtight without gaps or air leakage			
Heating/cooling devices are working			
Connected external devices are working			
The condensate easily flows from the unit and the drainage piping is watertight			
CF heat exchanger calibration performed (only in CF units)			
Other comments:			

Installer

Company

Tel. No.

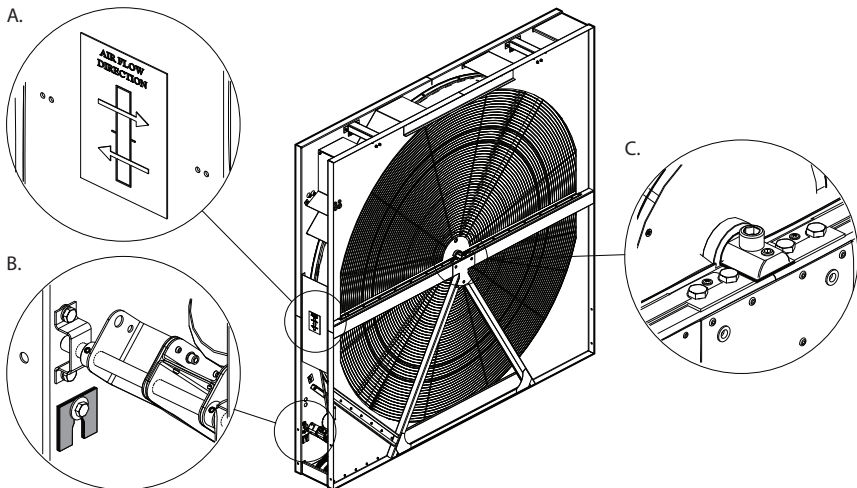
Date

Signature

## ANNEX NO. 1. ADJUSTMENT OF THE ROTARY HEAT EXCHANGER WHEEL

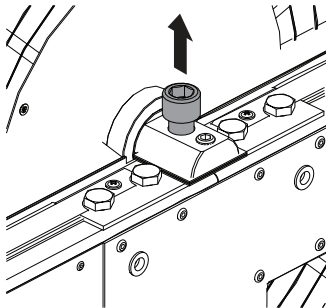
In the KLASIK 8 and larger units, a large-diameter rotary heat exchanger is used. Since, during the operation, the airflow constantly pushes the rotor wheel, due to its dimensions, to one side, it can eventually distort, causing the rotor sealing brushes and axle bearings to wear out faster or even may jam after time. To prevent this, check and, if necessary, adjust the position of the rotary wheel in relation to the section housing before connecting all the sections of the AHU. This is especially important if the mounting base is not completely level and the sections of the unit cannot be perfectly leveled using adjustable feet (see section "Requirements for the mounting location, installation base"). It is also recommended to check the position of the rotary wheel periodically, at least once a year.

1



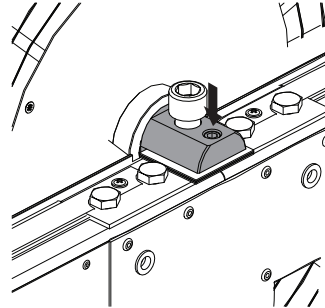
On the rotary heat exchanger housing, you will find a sticker A indicating the direction of the airflows in the unit. It is used to determine the tilting direction of the rotary wheel (see step 5). Wheel tilt regulation point C can be accessed from the side or from an adjacent section (if the unit sections are connected together). In the rotor section, you will also find additional adjustment plates B, that can be used, if the factory-installed adjustment plates are not sufficient to achieve the correct tilt angle.

2



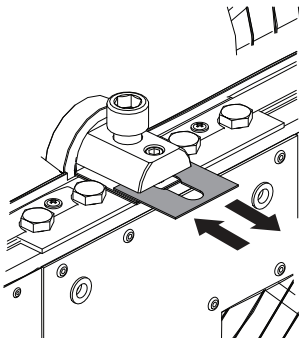
Loosen the fixing screw. Unscrew it from the shaft about 5 mm.

3



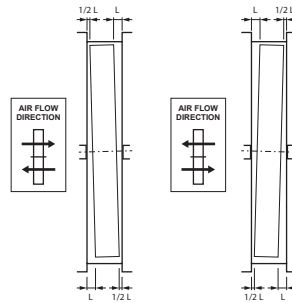
Screw in the adjusting screw. This will cause the wheel axis to tilt and release the adjustment plates.

4



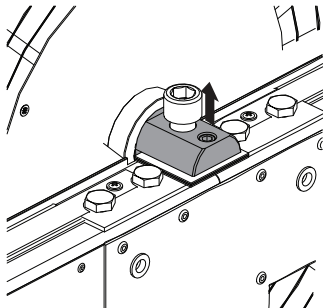
Remove or add the adjustment plates (depending on which side the wheel should be tilted).

5



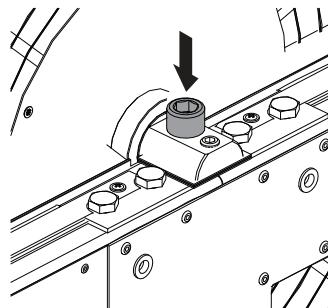
Tilt the heat exchanger axis so that the rotary wheel is slightly inclined against the direction of airflow. If the wheel cannot be adjusted correctly using the adjustment point on one side only, follow steps 2-4 on the other side of the rotor.

6



After adjusting the wheel tilt, loosen the adjusting screw so that the rotor shaft presses firmly against the adjusting plates.

7



Tighten the fixing screw.





## SERVICE AND SUPPORT

### LITHUANIA

#### UAB KOMFOVENT

Phone: +370 5 200 8000  
service@komfovent.com  
www.komfovent.com

### FINLAND

#### Komfovent Oy

Muuntotie 1 C1  
FI-01 510 Vantaa, Finland  
Phone: +358 20 730 6190  
toimisto@komfovent.com  
www.komfovent.com

### GERMANY

#### Komfovent GmbH

Konrad-Zuse-Str. 2a,  
42551 Velbert, Deutschland  
Phone: +49 0 2051 6051180  
info@komfovent.de  
www.komfovent.de

### LATVIA

#### SIA Komfovent

Bukaišu iela 1, LV-1004 Riga, Latvia  
Phone: +371 24 66 4433  
info.lv@komfovent.com  
www.komfovent.com

### SWEDEN

#### Komfovent AB

Ögärdesvägen 12A  
433 30 Partille, Sverige  
Phone: +46 31 487 752  
info\_se@komfovent.com  
www.komfovent.se

### UNITED KINGDOM

#### Komfovent Ltd

Unit C1 The Waterfront  
Newburn Riverside  
Newcastle upon Tyne NE15 8NZ, UK  
Phone: +447983 299 165  
steve.mulholland@komfovent.com  
www.komfovent.com

## PARTNERS

AT	J. PICHLER Gesellschaft m. b. H.	www.pichlerluft.at
BE	Ventilair group ACB Airconditioning	www.ventilairgroup.com www.acbairco.be
CZ	REKUVENT s.r.o.	www.rekuvent.cz
CH	WESCO AG SUDCLIMATAIR SA CLIMAIR GmbH	www.wesco.ch www.sudclimatair.ch www.climair.ch
DK	Øland A/S	www.oeland.dk
EE	BVT Partners	www.bvtpartners.ee
FR	ATIB	www.atib.fr
HR	Microclima	www.microclima.hr
HU	AIRVENT Légtechnikai Zrt. Gevent Magyarorszá g Kft. Merkapt	www.airvent.hu www.gevent.hu www.merkapt.hu
IE	Lindab	www.lindab.ie
IR	Fantech Ventilation Ltd	www.fantech.ie
IS	Blikk & Tækniþjónustan ehf Hitataekni ehf	www.bogt.is www.hitataekni.is
IT	ICARIA	www.icaria.srl
NL	Ventilair group DECIPOL-Vortvent CLIMA DIRECT BV	www.ventilairgroup.com www.vortvent.nl www.climadirect.com
NO	Ventilution AS Ventistål AS Thermo Control AS	www.ventilution.no www.ventistal.no www.thermocontrol.no
PL	Ventia Sp. z o.o.	www.ventia.pl
SE	Nordisk Ventilator AB	www.nordiskventilator.se
SI	Agregat d.o.o	www.agregat.si
SK	TZB produkt, s.r.o.	www.tzbprodukt.sk
UA	TD VECON LLC	www.vecon.ua